

# SPECIFICATIONS

# Blazer® - Double-Ended Reflector

Item #904944

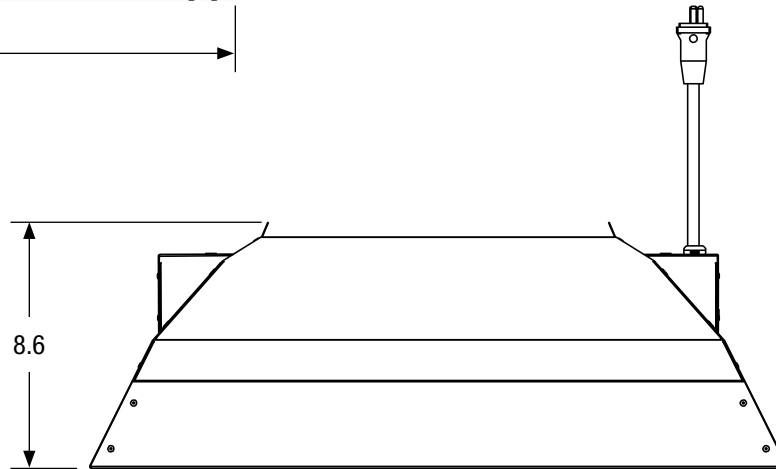
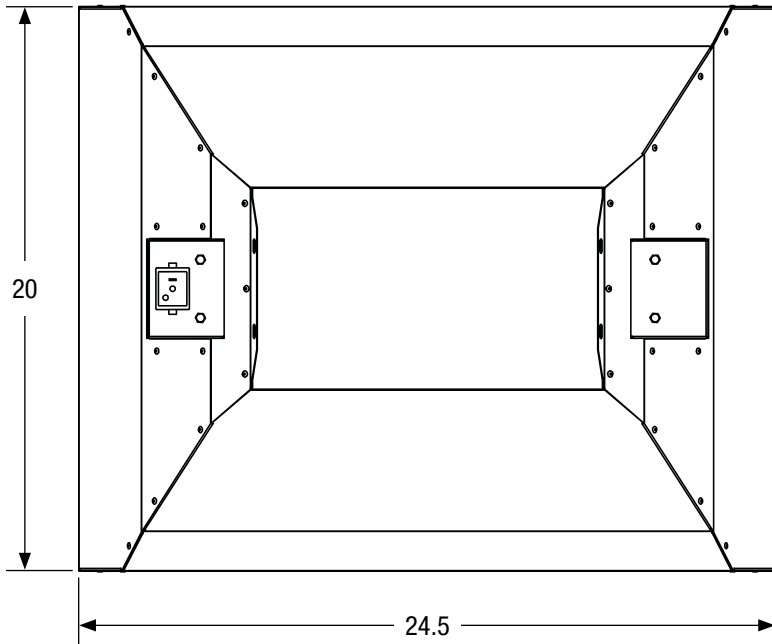

REFLECTOR WEIGHT: 9.7 lbs



*This document is not intended to be used for installation purposes. We cannot cover all specific applications or anticipate all requirements. All specifications are subject to change without notice.*

• = yes

•	ETL LISTED
	NOT ETL LISTED
<b>Tested to UL Standard #1598</b>	
	AIR-COOLED
	ACCEPTS GLASS
	HINGED GLASS FRAME
	DETACHABLE LAMP CORD
•	600 VOLT RATED CORD
	FABRICATED IN USA*
•	5 YEAR WARRANTY
<b>BALLAST COMPATIBILITY</b>	
•	HPS
	MH
<b>Max. Wattage: 1000</b>	
<b>LAMP COMPATIBILITY</b>	
•	HPS
	MH
<b>Max. Wattage: 1000</b>	
<b>LAMP POSITION</b>	
•	HORIZONTAL
	VERTICAL
<b>LAMP SOCKET TYPE</b>	
•	INTEGRATED DOUBLE-ENDED
	INTEGRATED 5KV MOGUL BASE

\* with US and globally sourced parts