

SPECIFICATIONS

Solartech Magnum™ Reflector

Item #904942



• = yes

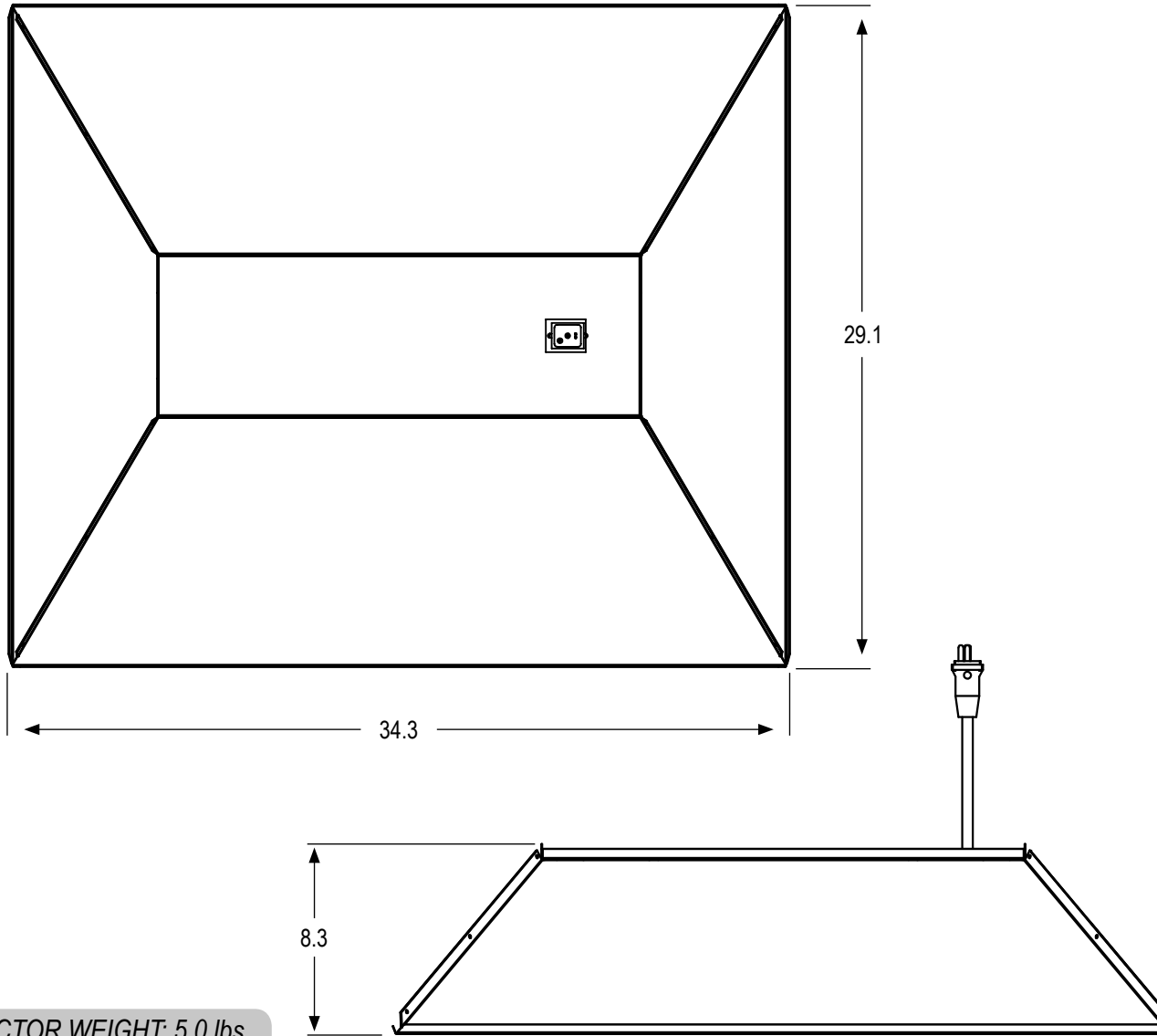

REFLECTOR WEIGHT: 5.0 lbs

•	ETL LISTED
	NOT ETL LISTED
Tested to UL Standard #1598	
	AIR-COOLED
	ACCEPTS GLASS
	HINGED GLASS FRAME
	DETACHABLE LAMP CORD
•	600 VOLT RATED CORD
	FABRICATED IN USA*
•	5 YEAR WARRANTY
BALLAST COMPATIBILITY	
•	HPS
•	MH
Max. Wattage: 1000	
LAMP COMPATIBILITY	
•	HPS
•	MH/O (Metal Halide/Open Rated)
Max. Wattage: 1000	
LAMP POSITION	
•	HORIZONTAL
	VERTICAL
LAMP SOCKET TYPE	
	INTEGRATED DOUBLE-ENDED
•	INTEGRATED 5KV MOGUL BASE

* with US and globally sourced parts



This document is not intended to be used for installation purposes. We cannot cover all specific applications or anticipate all requirements. All specifications are subject to change without notice.