

SPECIFICATIONS

DE Boss™ - Double-Ended Reflector

Item #904934

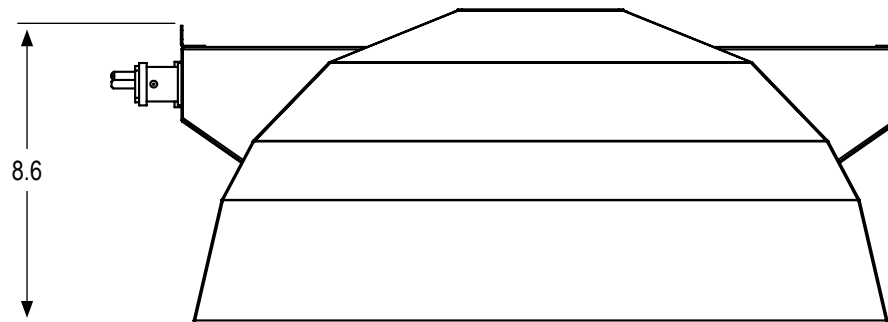
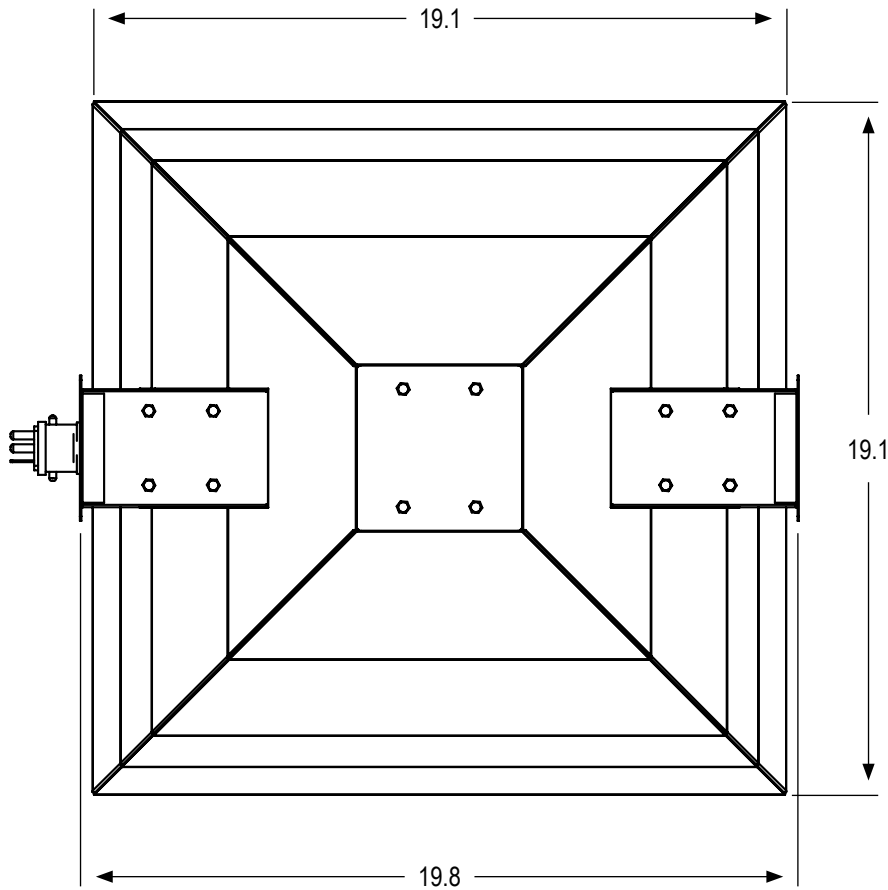

REFLECTOR WEIGHT: 7.3 lbs



This document is not intended to be used for installation purposes. We cannot cover all specific applications or anticipate all requirements. All specifications are subject to change without notice.

• = yes

•	ETL LISTED
	NOT ETL LISTED
Tested to UL Standard #1598	
	AIR-COOLED
	ACCEPTS GLASS
	HINGED GLASS FRAME
•	DETACHABLE LAMP CORD
•	600 VOLT RATED CORD
•	FABRICATED IN USA*
•	5 YEAR WARRANTY
BALLAST COMPATIBILITY	
•	HPS
	MH
Max. Wattage: 1000	
LAMP COMPATIBILITY	
•	HPS
	MH
Max. Wattage: 1000	
LAMP POSITION	
•	HORIZONTAL
	VERTICAL
LAMP SOCKET TYPE	
•	INTEGRATED DOUBLE-ENDED
	INTEGRATED 5KV MOGUL BASE

* with US and globally sourced parts