

SPECIFICATIONS

BlockBuster® 6 Inch Air-Cooled Reflector Generation 3

Item #904650



• = yes

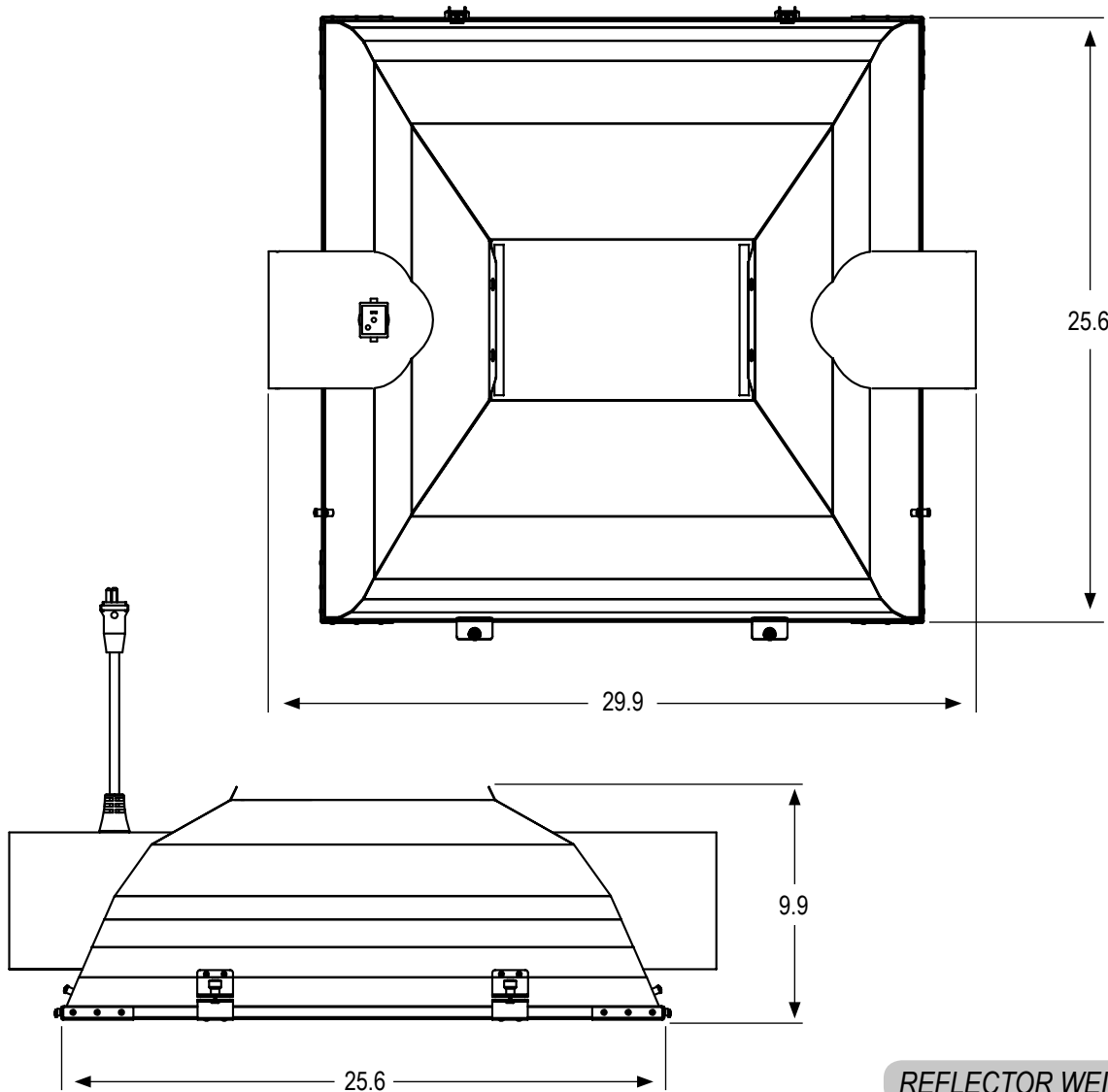

REFLECTOR WEIGHT: 23.0 lbs

•	ETL LISTED
	NOT ETL LISTED
Tested to UL Standard #1598	
•	AIR-COOLED
•	ACCEPTS GLASS
•	HINGED GLASS FRAME
	DETACHABLE LAMP CORD
•	600 VOLT RATED CORD
•	FABRICATED IN USA*
•	5 YEAR WARRANTY
BALLAST COMPATIBILITY	
•	HPS
•	MH
Max. Wattage: 1000	
LAMP COMPATIBILITY	
•	HPS
•	MH
Max. Wattage: 1000	
LAMP POSITION	
•	HORIZONTAL
	VERTICAL
LAMP SOCKET TYPE	
	INTEGRATED DOUBLE-ENDED
•	INTEGRATED 5KV MOGUL BASE

* with US and globally sourced parts