

# SPECIFICATIONS

# Parabolic 48 Inch Reflector

Item #904110

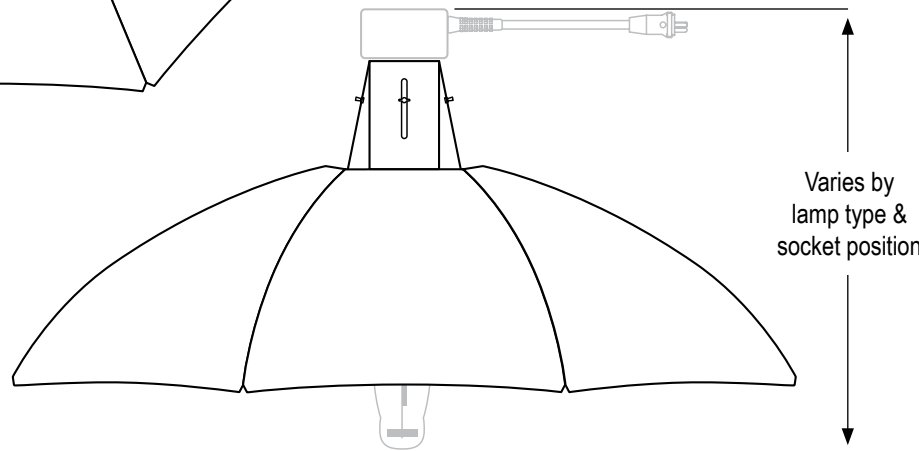
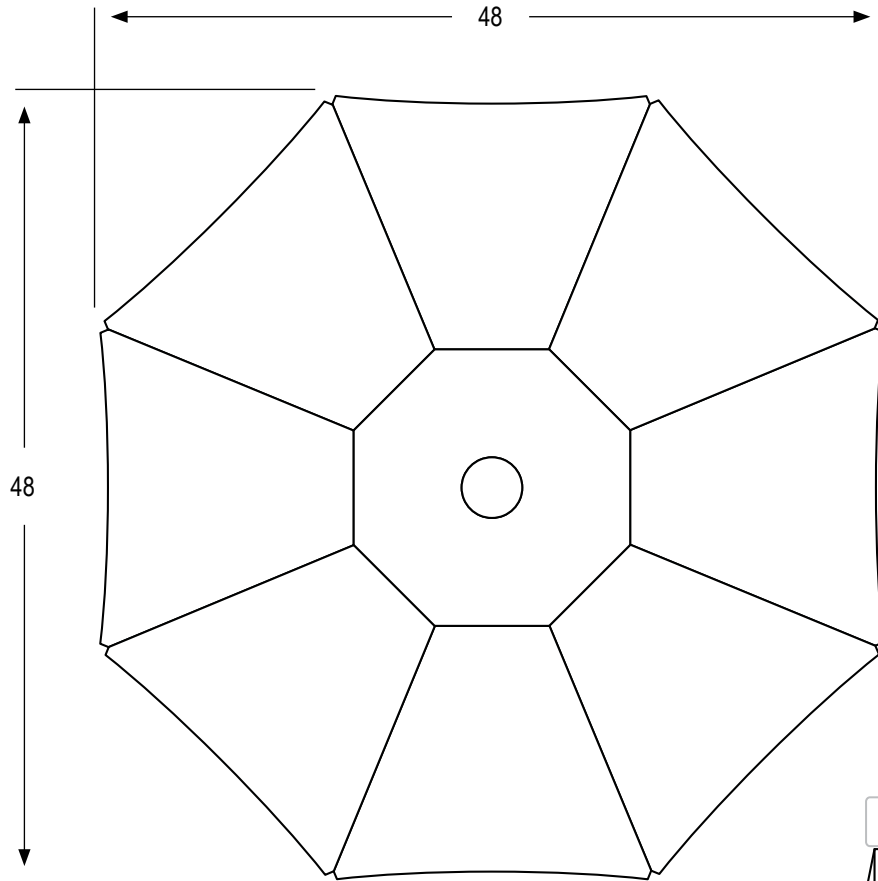

**REFLECTOR WEIGHT: 6.4 lbs**



*This document is not intended to be used for installation purposes. We cannot cover all specific applications or anticipate all requirements. All specifications are subject to change without notice.*

• = yes

•	ETL LISTED
	NOT ETL LISTED
<b>Tested to UL Standard #1598</b>	
	AIR-COOLED
	ACCEPTS GLASS
	HINGED GLASS FRAME
	DETACHABLE LAMP CORD
	600 VOLT RATED CORD
	FABRICATED IN USA*
•	5 YEAR WARRANTY
<b>BALLAST COMPATIBILITY</b>	
•	HPS
•	MH
<b>Max. Wattage: 1500</b>	
<b>LAMP COMPATIBILITY</b>	
•	HPS
•	MH (Protected Only)
<b>Max. Wattage: 1500</b>	
<b>LAMP POSITION</b>	
	HORIZONTAL
•	VERTICAL
<b>LAMP SOCKET TYPE</b>	
	INTEGRATED DOUBLE-ENDED
•	5KV MOGUL BASE**

\* with US and globally sourced parts

\*\* sold separately