

# Quest Dry RDS 10

## Installation, Operation and Maintenance Instructions

– Read and Save These Instructions –

*This manual is provided to acquaint you with the dehumidifier so that installation, operation and maintenance can proceed successfully. Ultimate satisfaction depends on the quality of installation and a thorough understanding of this equipment. The dehumidifier is built around tested engineering principles and has passed a thorough inspection for quality of workmanship and function.*

### Quest Dry RDS 10:

- Roto-mold design
- 80 pints per day at 80°F/60%RH (AHAM) (10 Gallons)
- 5.1 amps of power
- 12-inch recessed wheels
- Telescoping handle
- Solid state control panel
- Multiple ducting options
- Stackable design
- Lightweight



Patent 7,246,503

#### Water Removal Rate (Pints/Day)

**80 pints      80°F, 60% (AHAM)**



 **Therma-Stor<sup>®</sup> LLC**  
Driven by performance. Powered by design.™

4201 Lien Rd  
Madison, WI 53704  
[www.QuestOnTheJob.com](http://www.QuestOnTheJob.com)

Phone 608-237-8400  
Toll-Free 1-866-933-8476  
[sales@QuestOnTheJob.com](mailto:sales@QuestOnTheJob.com)

**Table of Contents**

Safety Precautions ..... 3

1. Safety Certifications..... 4

2. Specifications ..... 4

3. Operation..... 4

    3.1 Transporting ..... 4

    3.2 Electrical Requirements ..... 5

    3.3 Condensate Removal..... 5

    3.4 Ducting..... 5

    3.6 POWER Button..... 5

    3.7 PURGE Button ..... 5

    3.8 Hour Meter ..... 6

    3.9 HOURS Button ..... 6

    3.10 DEFROST Light ..... 6

4. Maintenance ..... 6

    4.1 Air Filter ..... 6

    4.2 Storage..... 6

5. Service ..... 7

    5.1 Technical Description..... 7

    5.2 Troubleshooting..... 7, 8

    5.3 Air Mover ..... 9

    5.4 Thermistor ..... 9

    5.5 Condensate Pump ..... 10

    5.6 Float Safety Switch ..... 10

6. Options and Accessories ..... 10

7. Wiring Diagram ..... 11

8. Service Parts ..... 12

Warranty ..... 13



## Safety Precautions

Read the installation, operation and maintenance instructions carefully before installing and operating this device. Proper adherence to these instructions is essential to obtain maximum benefit from your Quest Dry RDS 10.

### READ AND SAVE THESE INSTRUCTIONS

- The device is designed to be installed **INDOORS IN A SPACE THAT IS PROTECTED FROM RAIN AND FLOODING.**
- Install the unit with space to access the back or side panels for maintenance and service. **DO NOT INSTALL UNIT WITH THE SERVICE PANELS INACCESSIBLE.**
- Avoid directing the discharge air at people, or over the water in pool areas.
- If used near a pool or spa; be certain there is **NO** chance the unit could fall into the water, be splashed and that it is plugged into a **GFI GROUND FAULT INTERRUPT OUTLET.**
- **DO NOT use the device as a bench or table.**
- **DO NOT** place the device directly on structural members. Provide vibration isolation in order to minimize operational vibration and/or noise.
- A drain pan **MUST** be placed under the unit if installed above a living area or above an area where water leakage could cause damage



**1. Safety Certifications**

The Quest Dry RDS 10 conforms to standards ANSI/UL 474 and CSA C22.2 No.92.

**2. Specifications**

Part No.	4029630
Power	5.1 amps, 110-120 VAC, Grounded
Water Removal	80 pints/day @ AHAM (80°F, 60%) (10 Gallons)
Blower	230 CFM without external ducting 210 CFM @ .15 IWG external static
Refrigerant Charge	1 lb, 6 oz. R410A
Operating Range	33°F to 105°F
Filters:	12" x 12" x 1" Pleated Media MERV-7
Duct Options	Intake – 12" Flex-Duct Supply – 10" Lay-Flat
Warranty	Five years; 1st year 100% of Parts and Labor 2nd-5th year 100% of Parts of sealed refrigeration system.
Dimensions	Width 20", Depth 20", Height 33"
Weight	105 lbs.
Patent	<b>7,246,503</b>

**3. Operation**

Place dehumidifier inside structure, place condensate hose into a drain, or a very large container, and turn on. To decrease drying times, make sure all windows and doors are closed to the outside and seal off the wet area from any unaffected areas.

**3.1 Transporting**

The Quest Dry RDS 10 features a high-impact roto-molded housing which protects the unit airways, and while loading into vehicles. The unit was designed to make it easy to stack two high. The wheels of the top unit stack in the indentations of the bottom unit to provide stability. It is recommended the units are properly secured for transport. The Quest Dry



**Figure 1: Quest Dry RDS 10**



RDS 10 must always be upright when transported by vehicle. It may be tipped onto its handle and back for loading and moving by hand.

### 3.2 Electrical Requirements

The Quest Dry RDS 10 plugs into a common grounded outlet on a 15 amp circuit. It draws 5.1 amps at 80°F, 60% RH. If used in a wet area, a ground fault interrupter (GFI) is required. If an extension cord is required, it must have a minimum of 14 gauge conductors if 25 feet long or less and 12 gauge conductors if greater than 25 feet long.

### 3.3 Condensate Removal

The Quest Dry RDS 10 is equipped with an internal condensate pump to remove the water that is condensed during dehumidification. This allows the condensate to be pumped 20 feet with the attached hose. If the condensate must be pumped more than 20 feet above the unit, a second pump must be added to relay the condensate. The condensate pump automatically purges for 20 seconds every eight minutes. Use the PURGE button to manually remove condensation.

### 3.4 Ducting

A wire duct collar is supplied to allow 10" lay-flat duct to be attached to the Quest Dry RDS 10 outlet. Lay-flat plastic ducting is available; see accessories table page 6. To attach ducting to the wire duct collar, put the plastic duct end through the collar center and roll the duct end outward so that it overlaps the outside of the collar. The duct and collar may then be quickly attached to the Quest Dry RDS 10 by snapping the collar over the four exhaust tabs.

### 3.5 Defrost Cycle

If the low side refrigerant temperature drops due to excessive frost formation on the evaporator coil and below the temperature set point, the thermistor activates the solid-state control and defrost light. The compressor is cycled off and on by the thermistor temperature measurement. The air mover will continue to run, causing air to flow through the evaporator coil and melt the ice when the compressor is off. When the air temperature and/or humidity increases, the evaporator temperature will rise and the thermistor will end the defrost cycle at the temperature set point.

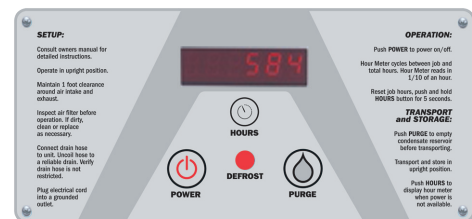

Figure 2: Quest Dry RDS 10 control board.

### 3.6 POWER Button

Press the POWER button to turn the dehumidifier on or off. When starting the dehumidifier the display will show the accumulated hours. Press the POWER button again to turn the dehumidifier off. The display will also power off.

### 3.7 PURGE Button

During normal operation the pump automatically cycles every four minutes. Press the PURGE button to remove condensate manually from the reservoir. There are several ways to manually remove water from the reservoir:

1. Press the PURGE button once and the pump will run for 20 seconds
2. Press and hold the PURGE button and the pump will run for up to 30 seconds
3. Press the PURGE button while the dehumidifier is powered off and the pump will run for 30 seconds.

Always manually purge the water reservoir before transport or storage. Turn off the power and allow the plugged in dehumidifier to rest 15 minutes before the final purge.



### 3.8 Hour Meter

The digital hour meter displays the amount of time the dehumidifier has been turned on to the tenth of an hour. The hour meter continuously cycles between total machine hours and job hours every 3 seconds. Hours are stored in memory even when the unit is unplugged. The previous totals will be displayed next time the unit is powered on.

### 3.9 HOURS Button

Pressing the HOURS button displays the hour meter when the unit is turned off but plugged into power. To reset job hours, press and hold the HOURS button for 5 seconds when the unit is operating.

### 3.10 DEFROST Light

The DEFROST light turns on when the unit is in defrost cycle and indicates when the compressor is off.

## 4. Maintenance

### 4.1 Air Filter

The Quest Dry RDS 10 is equipped with a pleated media air filter that must be checked regularly. The standard filter is a MERV-7 high efficiency filter. Operating the unit with a dirty filter will reduce the dehumidifier's capacity and efficiency and may cause the compressor to cycle off and on unnecessarily. The filter can generally be vacuumed clean several times before needing replacement. Replacement filters can be ordered from the manufacturer or purchased locally if available.

**IMPORTANT: DO NOT operate the unit without the filter or with a less effective filter as the heat exchanger and coils inside the unit could become clogged and require disassembly to clean.**

### 4.2 Storage

There are two issues to consider when the Quest Dry RDS 10 is stored between uses and both pertain to the water trapped in the unit: damage caused by freezing or biological growth. The effect of the trapped water can be greatly reduced if precautions are taken to remove as much as possible before storage.

1. Use the pump PURGE button to reduce the water level in the reservoir
2. Walk out the hose to drain it completely  
In order to reduce biological growth flush the unit with a biofungicide that is approved for use with copper, aluminum, polyethylene and ABS. To flush:
  1. Run the hose to a drain
  2. Plug in the unit but do not turn it on
  3. Remove the air filter. Slowly pour a pint of the chemical through the top so that it drains into the heat exchanger
  4. Use PURGE button to remove chemicals in reservoir. Run PURGE until hose runs dry
  5. Walk out hose to drain completely
  6. Replace air filter



## 5. Service

**WARNING:** Servicing the Quest Dry RDS 10 with its high pressure refrigerant system and high voltage circuitry presents a health hazard which could result in death, serious bodily injury, and/or property damage. Only qualified service people should service this unit.

**CAUTION:** Do not operate unit without the front housing in place.

### 5.1 Technical Description

The Quest Dry RDS 10 uses a refrigeration system similar to an air conditioner's to remove heat and moisture from incoming air and to add heat to the air that is discharged.

Hot, high pressure refrigerant gas is routed from the compressor to the condenser coil. The refrigerant is cooled and condensed by giving up its heat to the air that is about to be discharged from the unit. The refrigerant liquid then passes through a filter/drier and capillary tubing which cause the refrigerant pressure and temperature to drop. It next enters the evaporator coil where it absorbs heat from the incoming air and evaporates.

The evaporator operates in a flooded condition, which means that all the evaporator tubes contain liquid refrigerant during normal operation. A flooded evaporator should maintain constant pressure and temperature across the entire coil, from inlet to outlet.

The mixture of gas and liquid refrigerant enter the accumulator after leaving the evaporator coil. The accumulator prevents any liquid refrigerant from reaching the compressor. The compressor evacuates the cool refrigerant gas from the accumulator and compresses it to a high pressure and temperature to repeat the process.

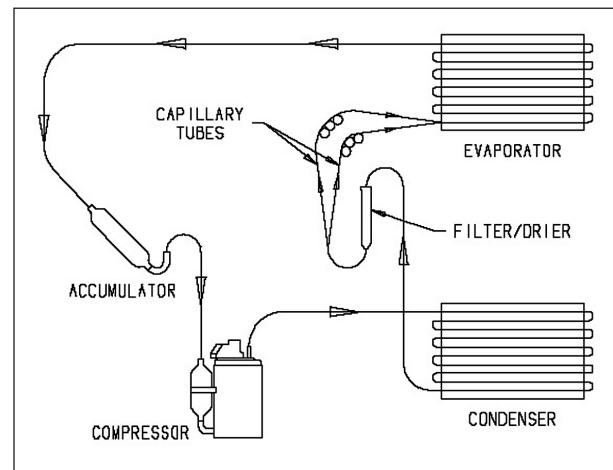

### 5.2 Troubleshooting

**No dehumidification, neither hour meter display nor compressor run and POWER button does not turn ON.**

1. Unit unplugged or no power to outlet
2. Defective control board
3. Loose connection in internal wiring

**No dehumidification, neither hour meter display nor compressor run with POWER button ON.**

1. Defective control board
2. Loose connection in internal wiring

**Some dehumidification, air mover runs continuously but compressor only runs sporadically.**

1. Unit is in defrost cycle, DEFROST light on
2. Defrost thermistor defective or loose
3. Loose connection in compressor circuit
4. Defective compressor overload
5. Defective compressor
6. Defective relay
7. Upper housing is not sealed to lower housing

**No dehumidification, air mover runs but compressor does not.**

1. Bad connection in compressor circuit
2. Safety float switch closed, check pump reservoir
3. Defective compressor capacitor
4. Defective compressor overload
5. Defective compressor
6. Defective control board

**Air mover does not run. Compressor runs briefly but cycles on and off.**

1. Loose connection in blower circuit
2. Obstruction prevents impeller rotation
3. Defective air mover

**Unit removes some water but not as much as expected.**

1. Air temperature and/or humidity have dropped
2. Humidity meter and/or thermometer used are out of calibration
3. Unit has entered defrost cycle
4. Air filter dirty
5. Defective defrost thermistor
6. Low refrigerant charge
7. Air leak such as loose cover
8. Defective compressor
9. Restrictive exhaust or inlet ducting

**Unit runs but does not pump water.**

1. Hose kinked or plugged
2. Pump motor defective
3. Pump check valve plugged
4. Bad connection in pump circuit
5. Hose disconnected internally
6. Defective control board (pump phase)





**Unit pumps water automatically but not when PURGE button is pushed.**

1. Bad connection in PURGE button circuit
2. Defective control board

**Evaporator coil frosted continuously, low dehumidifying capacity.**

1. Defrost thermistor loose or defective
2. Low refrigerant charge
3. Dirty air filter or restricted air flow
4. Upper housing is not sealed to lower housing

**Compressor runs with POWER button OFF.**

1. Defective relay
2. Defective control board
3. Upper housing not sealed to tower

**5.3 Air Mover**

The motorized impeller has a PSC motor and internal thermal overload protection. If defective, the complete assembly must be replaced.

1. Unplug power cord
2. Remove the four screws attaching the bottom plate to the lower housing
3. Disconnect the impeller leads
4. Remove the four screws holding the impeller to the bottom plate
5. Reassemble the new impeller using the above procedure in reverse

**5.4 Thermistor**

The defrost thermistor is attached to the refrigerant suction line between the accumulator and the evaporator.

To replace thermistor:

1. Unplug the dehumidifier
2. Remove the front housing
3. Cut cable ties and remove insulation and aluminum tape.
4. Remove control panel
5. Unthread thermistor from control housing grommet
6. Detach thermistor from control board jumper
7. Reassemble thermistor and dehumidifier using the above procedure in reverse



**Figure 4: Thermistor attached to the refrigerant line.**

**5.5 Condensate Pump**

The internal condensate pump removes water that collects in the reservoir.

To replace the condensate pump:

1. Unplug the unit
2. Remove the front housing
3. Unplug the pump wires from the wire harness
4. Remove the condensate hose and the one screw attaching the pump bracket to the compressor support
5. Replace the pump, hose, wiring, bolts, and housing in the reverse order

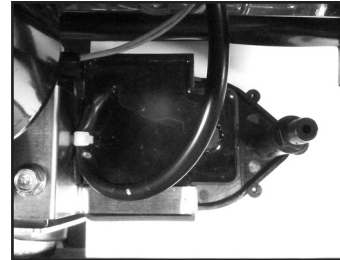

Figure 5: Picture of pump and float switch brackets screw.

**5.6 Float Safety Switch**

The float safety switch activates when the water rises too high in the condensate reservoir. The float safety switch turns off the compressor until the water level lowers and disengages the switch.

To replace the float safety switch

1. Unplug the dehumidifier
2. Remove the front housing
3. Unplug the float safety switch wires from the wire harness
4. Remove the one screw attaching the pump and float switch bracket to the compressor support
5. Remove the pump from the reservoir and slide out the float switch from under the compressor support
6. Replace the float, pump, wiring, bolts and housing in the reverse order

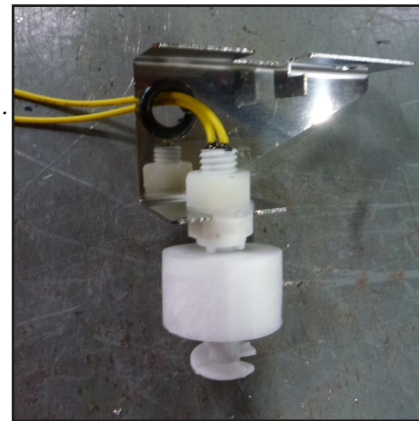

Figure 6: Picture of the float safety switch

**6 Options & Accessories**

- 4029498 Air Filter, Pleated 12: x 12" x 1" MERV-7 (Standard)
- 4029499 Air Filter, Pleated 12" x 12" x 1" MERV-11
- 4029521 Intake Flex Duct 12" x 25" Metallize Polyester
- 4029252 Lay-Flat Duct 10" Round x 250' Roll

To order, contact Therma-Stor LLC at 1-800-533-7533.



7. Wiring Diagram

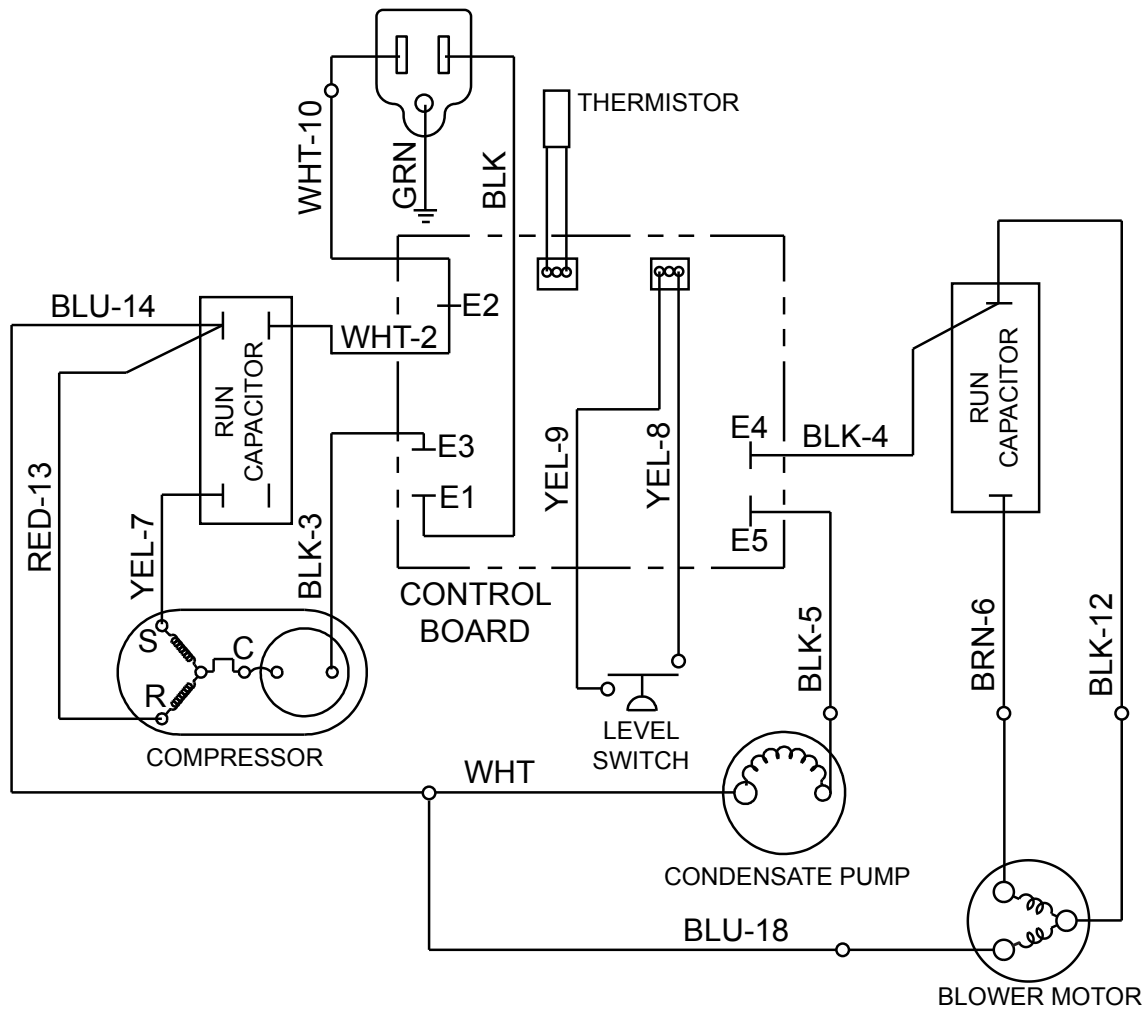
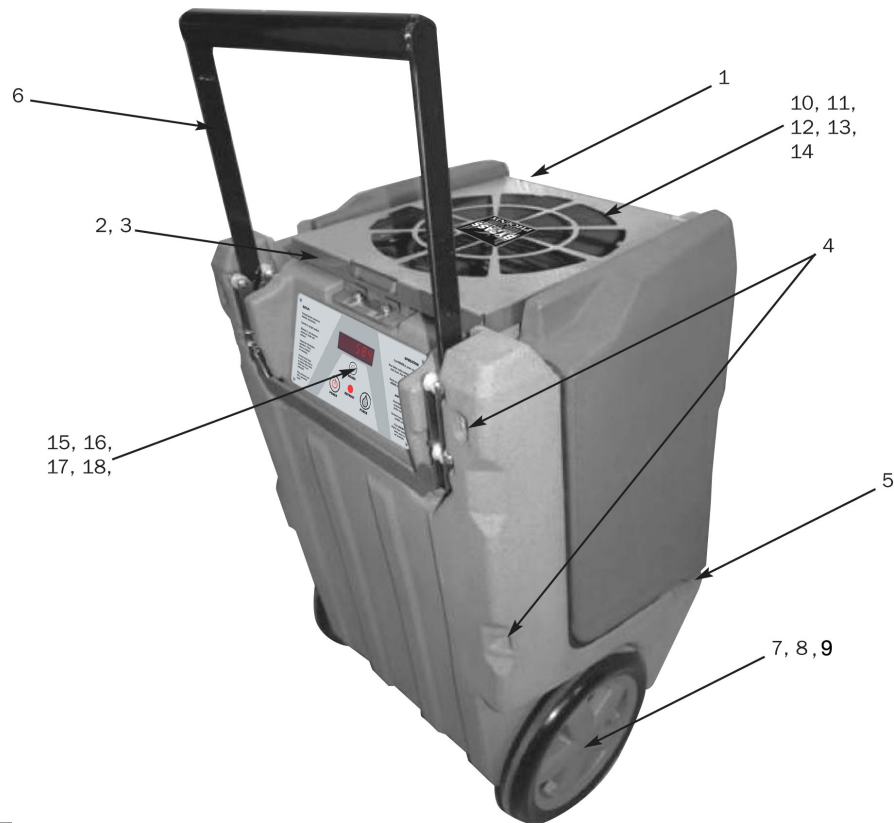

Figure 7

8. Service Parts

Item	Description	Qty	Part No.	<i>Items listed are not shown</i>		
1	Top Cover	1	4026977	<b>Description</b>	<b>Qty</b>	<b>Part No.</b>
2	Top Cover Hinge	2	4026978	Compressor	1	4029567
3	Top Cover Catch	1	4026979	Evaporator Coil	1	4028234
4	Hex Bolts, 1/4"-20 x 4"	4	1154019	Condenser Coil	1	4028235
5	Hex Bolts, 1/4"-20 x 1.75"	2	1154014	Accumulator	1	4028297
6	Handle Assembly	1	4027381	Condensate Pump	1	4034582-01
7	Wheel, 12"	2	4026851	Float Safety Switch	1	4034374
8	Cotter Pin	2	1284404	Impeller, Air Mover	1	4026360
9	Hub Cap, Wheel	2	4027138	Exhaust Grill	1	4026308
10	Filter, 12" x 12" x 1"	1	4026315	Wire Duct Collar	1	4026309
11	Hose (1/4" ID x 33' long)	1	4024916	Impeller Plate Bolt	4	1154006
12	Coupling Body, 1/4" Tube	1	4026306			
13	Coupling Insert, 1/4" Tube	1	4026986			
14	Cord	1	4032297			
15	Control Board	1	4026763			
16	Capacitor, Compressor, 35 µF	1	4033032-03			
17	Capacitor, Impeller, 7.5 µF	1	4033031-04			
18	Thermistor	1	4031279			



## Quest Dry RDS 10 Limited Warranty

**Warrantor:**

Therma-Stor LLC  
4201 Lien Rd  
Madison, WI 53704  
Telephone: 1-800-533-7533

**Who Is Covered:** This warranty extends only to the original end-user of the Quest Dry RDS 10 dehumidifier, and may not be assigned or transferred.

**Year One:** Therma-Stor LLC warrants that, for one (1) year the Quest Dry RDS 10 dehumidifier will operate free from any defects in materials and workmanship, or Therma-Stor LLC will, at its option, repair or replace the defective part(s), free of any charge.

**Year(s) Two Through Five:** Therma-Stor LLC further warrants that for a period of five (5) years, the condenser, evaporator, and compressor of the Quest Dry RDS 10 dehumidifier will operate free of any defects in material or workmanship, or Therma-Stor LLC, at its option, will repair or replace the defective part(s), provided that all labor and transportation charges for the part(s) shall be borne by the end-user.

**Year(s) One Through Seven:** Materials and workmanship of the housing are covered.

**End-User Responsibilities:** Warranty service must be performed by a Servicer authorized by Therma-Stor LLC. If the end-user is unable to locate or obtain warranty service from an authorized Servicer, he should call Therma-Stor LLC at the above number and ask for the Therma-Stor Service Department, which will then arrange for covered warranty service. Warranty service will be performed during normal working hours.

The end-user must present proof of purchase (lease) upon request, by use of the warranty card or other reasonable and reliable means. The end-user is responsible for normal care. This warranty does not cover any defect, malfunction, etc. resulting from misuse, abuse, lack of normal care, corrosion, freezing, tampering, modification, unauthorized or improper repair or installation, accident, acts of nature or any other cause beyond Therma-Stor LLC's reasonable control.

**Limitation and Exclusions:** If any Quest Dry RDS 10 Dehumidifier part is repaired or replaced, the new part shall be warranted for only the remainder of the original warranty period applicable thereto (but all warranty periods will be extended by the period of time, if any, that the Quest Dry RDS 10 Dehumidifier is out of service while awaiting covered warranty service).

UPON THE EXPIRATION OF THE WRITTEN WARRANTY APPLICABLE TO THE Quest Cool ACS 12 OR ANY PART THEREOF, ALL OTHER WARRANTIES IMPLIED BY LAW, INCLUDING MERCHANTABILITY AND FITNESS FOR A PARTICULAR PURPOSE, SHALL ALSO EXPIRE. ALL WARRANTIES MADE BY THERMA-STOR LLC ARE SET FORTH HEREIN, AND NO CLAIM MAY BE MADE AGAINST THERMA-STOR LLC BASED ON ANY ORAL WARRANTY. IN NO EVENT SHALL THERMA-STOR LLC, IN CONNECTION WITH THE SALE, INSTALLATION, USE, REPAIR OR REPLACEMENT OF ANY Quest Cool ACS 12 OR PART THEREOF BE LIABLE UNDER ANY LEGAL THEORY FOR ANY SPECIAL, INDIRECT OR CONSEQUENTIAL DAMAGES INCLUDING WITHOUT LIMITATION WATER DAMAGE (THE END-USER SHOULD TAKE PRECAUTIONS AGAINST SAME), LOST PROFITS, DELAY, OR LOSS OF USE OR DAMAGE TO ANY REAL OR PERSONAL PROPERTY.

Some states do not allow limitations on how long an implied warranty lasts, and some do not allow the exclusion or limitation of incidental or consequential damages, so one or both of these limitations may not apply to you.

**Legal Rights:** This warranty gives you specific legal rights, and you may also have other rights which vary from state to state.

