

IMPORTANT

Product defect? Not working properly?

DO NOT return this product to the store where you purchased it.

Contact Ideal Air Support directly at support@ideal-air.com or call

1-877-9-IDEAL-1

For answers to the most common questions and a complete technical support library please visit www.ideal-air.com

For warranty claims contact the Customer Care Center

1-866-646-4332

IDEALair™

5408 NE 88th St., Bldg. A
Vancouver, WA 98665

www.ideal-air.com

A division of Sunlight Supply

All design and specifications herein are subject to change without notice for product improvement. Contact Ideal Air for details, updates and other information.

OWNER'S MANUAL

IDEALair™

Portable Air Conditioner

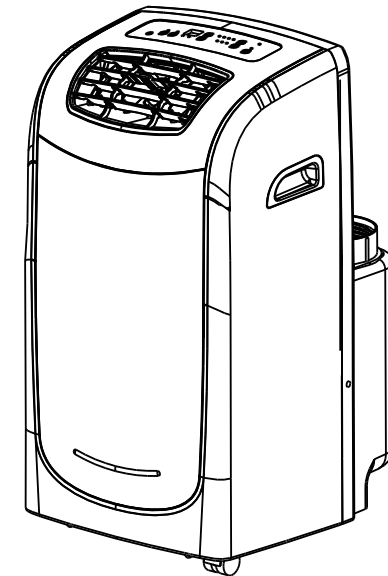

IMPORTANT!

Before operating this product, please read the instructions carefully and save this manual for future use.

PLEASE BE RESPONSIBLE

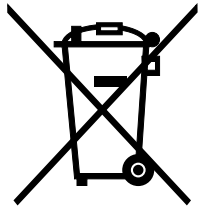

DO NOT dispose of this product in the trash, on the landscape or into any unsorted waste stream!

It may contain hazardous substances that can leach into groundwater and find their way into the food chain.



This unit contains VALUABLE RESOURCES that are easy to turn in for recycling and re-use. Services available may include:

- A. Municipal Collection Systems:** Most cities and towns have established programs where electronic waste can be turned in for recycling free of charge.
- B. Retailer Return:** When buying a new product, many retailers will take back an old product free of charge.
- C. Manufacturer Return:** Many manufacturers accept old products for recycling free of charge.
- D. Scrap Dealers:** Many scrap dealers will buy old electronics or take them free of charge.

SAFETY PRECAUTIONS 2 - 3

PARTS IDENTIFICATION 4 - 5

CONTROL PANEL
 Overview and Operation 6 - 7

INSTALLATION
 Unit Placement 8
 Window Slider Kit Installation 8
 • Installation in a Vertical Window 9
 • Installation in a Horizontal Window 10
 Connecting Intake and Exhaust Hoses 11
 Vent Control Feature 11
 Water Drainage 11

CARE & MAINTENANCE 12

TROUBLESHOOTING TIPS 13

WARRANTY 14

NOTE

Rating data on the energy label is based on installation of a standard, unextended air exhaust duct without Adapter A & B (shown in "Optional Accessories" section on Page 4).

Safety Precautions

To prevent injury to the user or other people and property damage, the following instructions must be followed. Incorrect operation due to ignoring of instructions may cause harm or damage.

Always do this

- Your air conditioner should be used so that it is protected from moisture, condensation, splashed water, etc. Do not place or store where it can fall or be pulled into water or any other liquid. If so, unplug immediately.
- Always transport your air conditioner in a vertical position and stand on a sturdy, stable and level surface during use.
- Turn off the product when not in use.
- Always contact a qualified person to carry out repairs. If the supply cord is damaged it must be repaired by a qualified repairer.
- Keep an air path of at least 12" (30cm) all around the unit, away from walls, furniture and curtains.
- If the air conditioner is knocked over during use, turn off the unit and unplug from the power supply immediately.

Never do this

- Do not operate your air conditioner in a wet room such as a bathroom or laundry room.
- Do not touch the unit with wet or damp hands or when barefoot.
- Do not press the buttons on the control panel with anything other than your fingers.
- Do not remove any fixed covers. Never use this appliance if it is not working properly or if it has been dropped or damaged.
- Never use the plug to start and stop the unit.
- Always use the switch on the control panel.
- Do not cover or obstruct the inlet or outlet grilles.
- Do not use hazardous chemicals to clean or come into contact with the unit. Do not use in the presence of flammable substances or vapors such as alcohol, insecticides, petrol, etc.
- Do not allow children to operate the unit unsupervised.
- Do not use this product for functions other than those described in this instruction manual.

Energy Save

- Use the unit in the recommended room size.
- Locate the unit where furniture cannot obstruct the air flow.
- Keep blinds/curtains closed during the sunniest part of the day.
- Keep the filters clean.
- Keep doors and windows closed to keep cool air in and warm air out.

OPERATING TEMPERATURES

This air conditioner must be operated within the temperature ranges indicated below or performance may be reduced.

MODE	ROOM TEMPERATURE
COOL	62°F (17°C) to 95°F (35°C)
DRY (dehumidify)	55°F (13°C) to 95°F (35°C)
HEAT (heat pump)	41°F (5°C) to 88°F (30°C)
HEAT (element)	88°F (30°C)

Suggested tools for window kit installation:

- Screwdriver (medium size Phillips)
- Knife or scissors
- Tape measure or ruler
- Saw (if window kit needs to be trimmed down to fit window)

Safety Precautions

NOTE On some models, the power supply cord contains a current detection device to reduce the risk of fire. Please refer to the "Operation" section for details. If the power supply cord is damaged, it cannot be repaired. It must be replaced with a cord from the manufacturer.

WARNING For your safety

- Do not store or use gasoline or other flammable liquids or vapors in the vicinity of this or any other appliance.
- Avoid fire hazard or electric shock. Do not use an extension cord or an adapter plug. Do not remove any prong from the power cord.

WARNING Electrical Information

- Be sure the electrical service is adequate for the model you have chosen. This information can be found on the serial plate, which is located on the side of the cabinet and behind the grille.
- Be sure the air conditioner is properly grounded to minimize shock and fire hazards. The power cord is equipped with a three-prong grounded plug for protection against shock hazards.
- Your air conditioner must be used with a properly grounded all receptacle. If the receptacle you intend to use is not adequately ground or protected by a fuse or circuit breaker, have a qualified electrician install the proper receptacle.
- Ensure that the receptacle is accessible after the unit is installed.

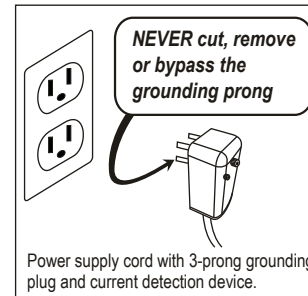

How to operate the current detection device:

The power supply cord on your unit may contain a current detection device that can sense damage to the power cord. To test this device:

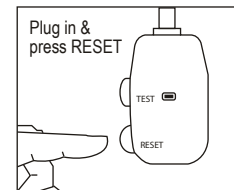

NOTE: Some plugs have buttons on the top.

1. Insert current detection plug into wall receptacle.
 2. The plug will have TWO buttons: "Test" and "Reset." Press the "Test" button and you will hear a click as the "Reset" button pops out.
 3. Press the "Reset" button in. You will hear another click as the button engages, safely connecting the unit to the power supply.
 4. The power supply cord is now supplying current to the unit.
- DO NOT use this device to turn the unit on or off.
 - ALWAYS make sure the "Reset" button is pushed in for operation.
 - Plug MUST be replaced if it fails "Reset" when either the "Test" button is pushed or it cannot be reset. Obtain a new plug and cord from the manufacturer.
 - If power supply cord is damaged, it cannot be repaired. It MUST be replaced by one from the manufacturer.

Parts Identification

ACCESSORIES INCLUDED:

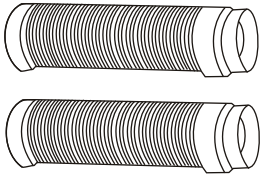

Standard intake and exhaust hoses with adapter (2)

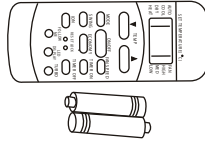

Remote control and batteries (remote control models only)

Check to make sure included accessories are in the package. Refer to installation instructions for correct use.

OPTIONAL ACCESSORIES:

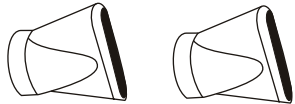

Window intake and exhaust hose adapters (2)

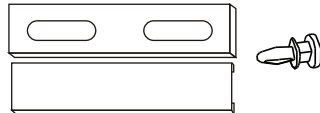

Window slider kit and bolt (designed for adapters at left)

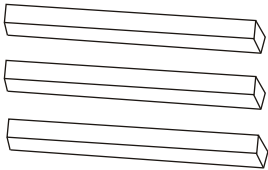

Foam window seals (3)

To order Optional Accessories visit www.ideal-air.com or call 1-877-9-IDEAL-1.

Parts Identification

FRONT

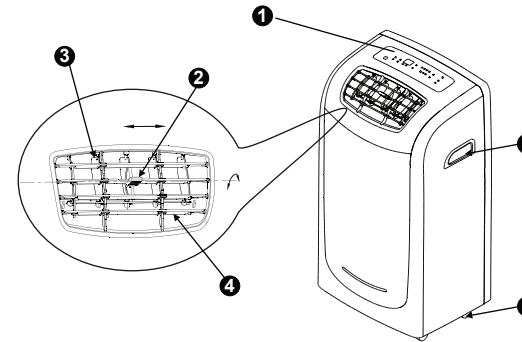

- 1 Control Panel
- 2 Blades Control Handle
- 3 Vertical Louver Blade
- 4 Horizontal Louver Blade
- 5 Carrying Handle (both sides)
- 6 Caster

REAR

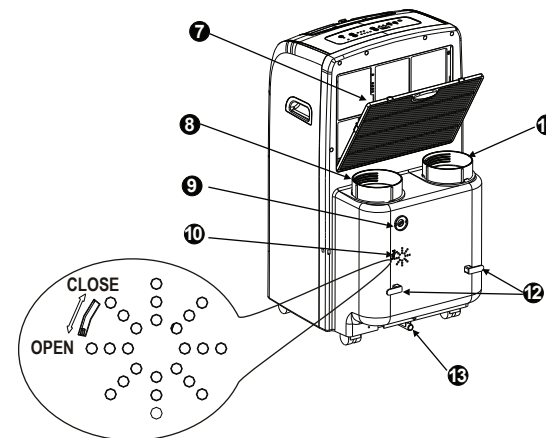

- 7 Air Filter
- 8 Intake Port
- 9 Drain Outlet
- 10 Vent Control
- 11 Exhaust Port
- 12 Power Cord Caddy
- 13 Bottom Drain Outlet

Control Panel

Before operating your air conditioner, thoroughly familiarize yourself with the Control Panel, Remote Control and all of their functions (see Remote Control Instructions packaged with the remote).

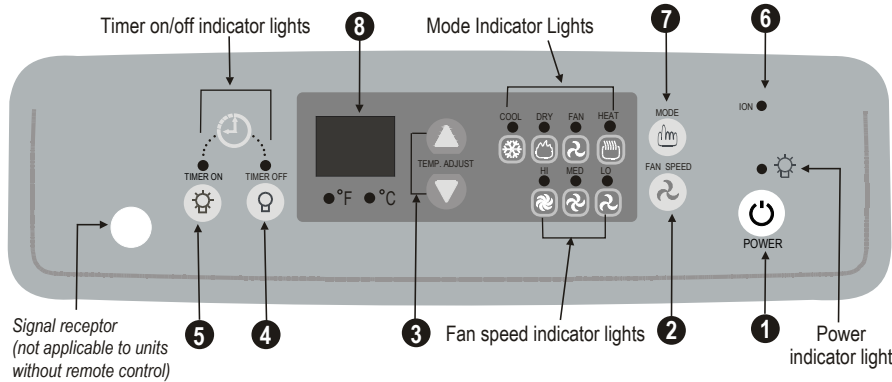

NOTE: The Control Panel on the unit you purchased may be slightly different than shown.

1 Power ON/OFF

2 Fan Speed

Press to select fan speed in 3 steps: HI, MED and LOW. Note: when all fan speed indicators are off, fan speed is set to AUTO which is only selected via the remote control.

Fan Speed Options:

- COOL (3 speeds): HI-MED-LO
- DRY (1 speed): LO
- FAN (3 speeds): HI-MED-LO
- HEAT (3 speeds): HI-MED-LO

3 Temp. Adjust

Adjust temperature up or down in in 2°F (1°C) increments ranging from 62°F (17°C) to 88°F (30°C). Also used to adjust timer settings.

NOTE: To set display between °F or °C, press and hold up and down Temp. Adjust buttons together for 3 seconds.

4 Timer OFF

Press to initiate or cancel the Auto Stop program. Use ▲ ▼ to set values.

5 Timer ON

Press to initiate or cancel the Auto Start program. Use ▲ ▼ to set values.

6 ION Indicator (optional)

To turn Ionizer ON or OFF, press and hold the "Fan Speed" button for 3 seconds.
For units with Ionizer installed only.

7 MODE Select

Selects appropriate operating mode. Each time you press the button, a different mode is selected from COOL, DRY, FAN and HEAT. The corresponding indicator light will come on with mode selected.

8 LED Display

Displays set temperature in °F or °C. Also displays timer settings.

Control Panel

Operating MODES

COOL 62°F to 95°F (17°C to 35°C)

1. Press "Mode" button until the "COOL" indicator light comes on.
2. Press "Temp. Adjust" buttons ▲▼ to select desired room temperature from 62°F to 88°F (17°C to 30°C).
3. Press "Fan Speed" button to choose fan speed.

NOTE: Some models limit fan speed to LOW when room temperature is 98°F (37°C) or higher. The system will not resume a previous fan speed setting until the room temperature falls below 93°F (35°C).

DRY 54°F to 95°F (13°C to 35°C)

Press "Mode" button until the "DRY" (dehumidifying) indicator light comes on.

- Under this mode, you cannot select a fan speed or adjust the temperature. The fan motor operates at LOW speed only.
- Keep windows and doors closed for the best dehumidifying performance.
- Do not connect intake and exhaust ports to window.

CAUTION: During COOL or DRY modes, if unit power is interrupted (unplugged, power failure, etc.) and then immediately restored, a compressor protection circuit is activated. The compressor cannot operate for about 3 minutes until the circuit self-deactivates.

HEAT 41°F to 88°F (5°C to 30°C)

For units with PTC only

1. Press "Mode" button until the "HEAT" indicator light comes on.
2. Press "Temp. Adjust" buttons ▲▼ to select desired room temperature from 62°F to 88°F (17°C to 30°C).
3. Press "Fan Speed" button to choose fan speed.

Do not connect intake and exhaust ports to window. For some models fan speed is limited to LOW in HEAT mode.

FAN All temperatures

1. Press "Mode" button until the "FAN" indicator light comes on.
2. Press "Fan Speed" button to choose fan speed. The temperature cannot be adjusted.

Do not connect intake and exhaust ports to window.

AUTO FOR REMOTE CONTROL

When the unit is set to "AUTO" operation, all functions are transferred to the remote control. All "Mode" and "Fan Speed" indicator lights will be dark in AUTO mode. See Remote Control Instruction Guide for control of unit functions.

Setting the Timer (Timer must be set with unit Power OFF)

1. With the unit Power OFF, press the "Timer On" button to activate the Auto Start program.
2. When the Auto Start program is initiated, press the ▲▼ buttons to adjust times up or down in increments of 0.5 hour up to 10 hours – then at 1 hour increments up to 24 hours.
3. Repeat steps #1 and #2 to set the Auto Stop program.
4. When Auto Start and Auto Stop times are set within the same program sequence, the "Timer On" and "Timer Off" indicator lights illuminate to indicate that both ON and OFF times are now programmed.

NOTE: Time settings will display for only 5 seconds, so you should continue pressing the ▲▼ buttons until desired time is reached.

ERROR/PROTECTION CODES

- E1 – Evaporator temperature sensor error. Unplug unit and plug back in. If error repeats, call for service.
- E2 – Room temperature sensor error. Unplug unit and plug back in. If error repeats, call for service.
- P1 – Bottom tray is full of water. Remove drain plug and remove collected water.

Installation

Air Conditioner Placement

- The air conditioner should be placed on a firm surface to minimize noise and vibration. For safe and secure operation, place the unit on a smooth, level floor strong enough to support it.
- The unit has casters to aid in moving but it should only be rolled across smooth, flat surfaces. Use caution when rolling on carpeted surfaces. Do not attempt to roll the unit over objects.
- The unit must be placed within reach of a properly rated and grounded socket.
- Allow at least 12" (30cm) of space from the wall for efficient air conditioning. (Fig. 1)

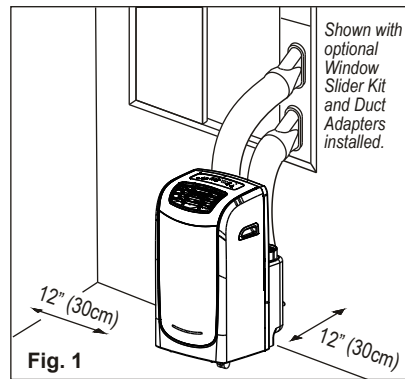

Window Slider Kit Installation

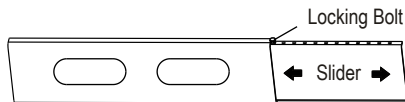

Your optional, 2-piece Window Slider Kit has been designed to fit most standard vertical and horizontal windows (Fig. 2 & 3). However, it may be necessary to cut the Slider shorter to fit windows that are less than 2.22 ft. (67.5 cm) wide (Type I) or less than 1.84 ft. (56.2 cm) wide (Type II). See Fig. 4 below for minimum and maximum window openings (A) that the Window Slider Kit will fit *without* modification.

Fig. 4

	A
TYPE I	2.22 to 4.04 ft. (67.5 – 123 cm)
TYPE II	1.84 to 3.22 ft. (56.2 – 98.2 cm)

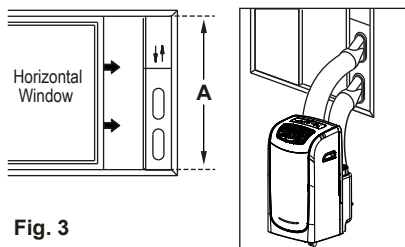
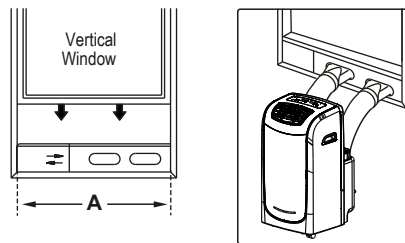

Installing the Window Slider Kit in a Vertical, Double-Hung Sash Window

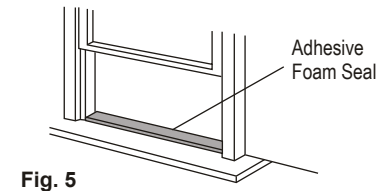

1. Cut 1 piece of Adhesive Foam Seal to the proper length, raise the window sash and attach the foam to the window stool (Fig. 5)

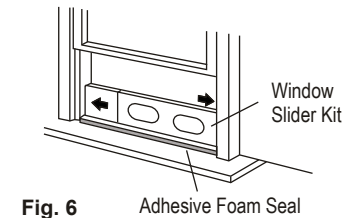

2. Adjust the length of the Window Slider Kit to the width of the window. Shorten the Slider if the width of the window is less than 26.5" (Type I) or 22.1" (Type II). Place the Window Slider kit on top of the Adhesive Foam Seal (Fig. 6)

3. Cut another piece of Adhesive Foam Seal to the proper length and attach it to the top of the Window Slider Kit. Close the window sash securely against the Top of the Window Slider Kit (Fig. 7).

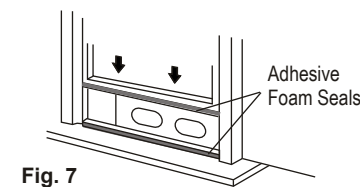

4. Cut a third piece of Adhesive Foam Seal to the appropriate length to seal any gap between the top window sash and outer window sash (Fig. 8).

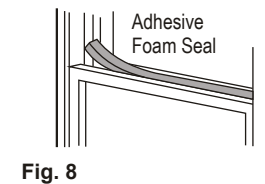

Installing the Window Slider Kit in a Horizontal Sliding Sash Window

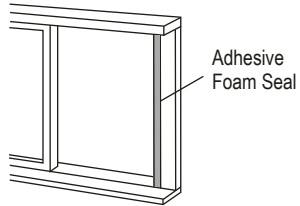

Fig. 9

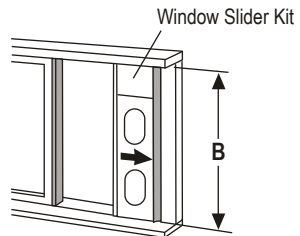

Fig. 10

	B
TYPE I	26.5" to 48"
TYPE II	22.1" to 38.6"

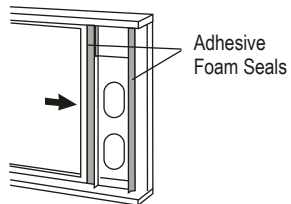

Fig. 11

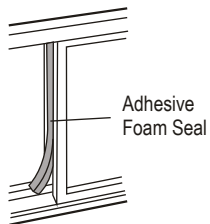

Fig. 12



1. Cut 1 piece of Adhesive Foam Seal to the proper length, open the window and attach the foam to the side of the window frame (Fig. 9)
2. Adjust the length of the Window Slider Kit to the height of the window. Shorten if the height of the window is less than 26.5" (Type I) or 22.1" (Type II). Place the Window Slider Kit into the window opening with one side snugly against the foam (Fig. 10)
3. Cut another piece of Adhesive Foam Seal to the proper length and attach it to the other side of the Window Slider Kit. Close the sliding sash securely against the side of the Window Slider Kit (Fig. 11).
4. Cut a third piece of Adhesive Foam Seal to the appropriate length to seal any gap between the window sashes (Fig. 12).

Connecting Intake and Exhaust Hoses

1. Install flexible intake and exhaust hoses on collars in the back of the unit (Fig. 13).
2. Install Adapter B on the other end of hoses (Fig. 14) and insert into Window Slider Kit openings (see previous pages for Window Slider Kit installation).

Hoses can be stretched if necessary, but should be kept to the shortest length possible.

IMPORTANT: Do not overbend the hoses. Make sure there are no obstacles near the air intake or exhaust outlet so the system vents properly.

-  **CONNECT EXHAUST HOSE** when unit is in COOL, HEAT (heat pump) or AUTO mode.
-  **DISCONNECT EXHAUST HOSE** when unit is in FAN, DEHUMIDIFY or HEAT (element) mode.

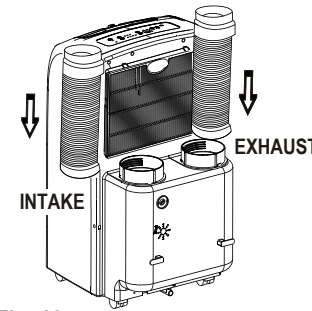

Fig. 13

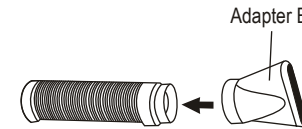

Fig. 14

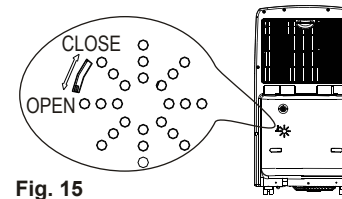

Fig. 15

Vent Control Feature

The Vent Control is located on the back of the unit (Fig. 15). The OPEN position removes stale air from the room and exhausts it to the outside. Fresh air is drawn in through normal passages in the home. When room air venting is not needed, set Vent Control to CLOSE.

Water Drainage

"DRY" (dehumidify) Mode

1. Remove drain plug from the back of the unit (Fig. 16).
2. Connect standard 5/8" garden hose (not included).
3. Route hose to secure drain. Make sure there are no kinks and the hose drains freely.

NOTE: For double duct design, water drainage is not required during regular cooling operation. Connecting a drain hose will actually reduce efficiency.

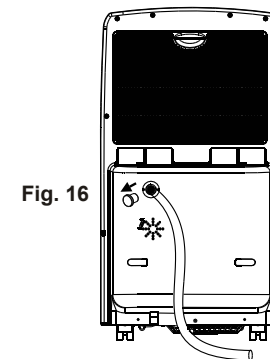

Fig. 16

Care and Maintenance

IMPORTANT:

1. Be sure to unplug the unit from the power supply before cleaning or servicing.
2. Do not use gasoline, thinner or other chemicals to clean the unit.
3. Do not wash the unit directly under a tap or use a hose (Fig. 17). Getting moisture inside the unit will cause an electrical hazard.
4. If the power cord is damaged, it must be repaired or replaced by the manufacturer.

Cleaning the Air Filter

Clean the air filter at least once every two weeks to prevent dust buildup that will reduce efficiency.

TO REMOVE: Grasp the air filter tab and pull out and up (Fig. 18).

TO CLEAN: Wash the air filter by immersing it gently in warm water with a mild detergent. Rinse and dry away from direct sunlight.

TO REPLACE: Insert bottom of filter behind lower tabs in opening. Push top in and snap into place.

Cleaning the Enclosure

Use a lint free cloth and mild detergent to clean the enclosure. Dry with a clean cloth.

Storing the Unit

1. Remove the rubber plug from the bottom drain tray (Fig. 19). Attach an appropriate drain hose to remove any water that has accumulated in the tray. When drain tray is completely dry, replace the rubber drain plug.
2. Run the unit in FAN mode for about half a day in a warm room, thoroughly drying the inside of the unit to prevent the growth of mold, mildew and bacteria.
3. Power OFF the unit, unplug it from the wall receptacle and wind the power cord around the cord caddy (Fig. 20). Don't forget to remove the batteries from the remote and store them in a separate plastic bag.
4. Remove the air filter, clean and reinstall it.
5. Disconnect exhaust hose, store it securely and cover the window openings.

NOTE: Check to make sure tray drain plug is present when removing the unit from storage and returning it to use.

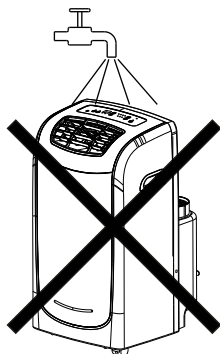

Fig. 17

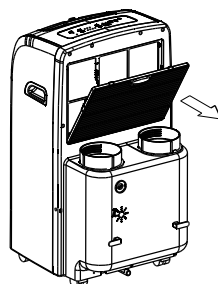

Fig. 18

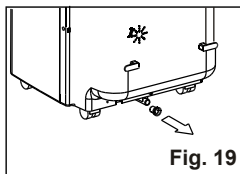

Fig. 19

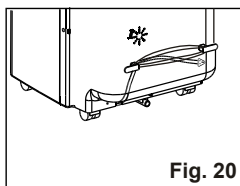

Fig. 20

Troubleshooting Tips

Before calling service, review the chart below.

You may be able to quickly resolve the problem yourself.

PROBLEM	POSSIBLE CAUSE	SOLUTION
Unit doesn't start when Power ON is pressed.	Room temperature is higher than the set temperature (HEAT mode)	Reset the temperature to a higher value.
	Room temperature is lower than the set temperature (COOL mode)	Reset the temperature to a lower value.
Unit not cooling enough.	The windows or doors in the room are not closed.	Make sure all windows and doors are closed.
	There are heat sources inside the room.	Remove or turn off heat sources if possible.
	Exhaust air duct is not connected or blocked.	Connect exhaust duct and make sure it is not obstructed.
	Temperature setting is too high.	Decrease the set temperature.
Air filter is blocked by dust.		Clean the air filter.
Unit shutting off during HEAT mode.	Automatic heat protection function has been activated. When the temperature at the air outlet exceeds 158°F (70°C) the unit will Power OFF.	Power ON again after the unit has cooled down.
Noise or vibration during operation.	Unit is not on a flat, level surface.	Move unit to a flat, level surface.
Gurgling sounds coming from unit.	Refrigerant is flowing inside the unit.	Normal, no action required.
Compressor doesn't work and digital display shows "P1".	The bottom tray is full of water.	Remove rubber plug from drain tray and drain water.

Ideal Air Conditioner Warranty

Your product is protected by this warranty:

Warranty service must be obtained from Midea Consumer Services or an authorized Midea servicer.

Warranty

- One year full warranty from original purchase date.
- Limited 2nd through 5th year sealed system warranty*

Midea, through its authorized servicers will:

- Pay all costs for repairing or replacing parts of this appliance which prove to be defective in materials or workmanship.
- *For limited 2nd through 5th year sealed system warranty, Midea will replace any part in the sealed refrigeration system (compressor, condenser, evaporator and tubing) which proves to be defective in materials or workmanship.

Consumer will be responsible for:

- Diagnostics, removal, transportation and reinstallation cost required because of service.
- Costs of service calls that are a result of items listed under **NORMAL RESPONSIBILITIES OF THE CONSUMER****

Midea replacement parts shall be used and will be warranted only for the period remaining on the original warranty.

NORMAL RESPONSIBILITIES OF THE CONSUMER**

This warranty applies only to products in ordinary household use, and the consumer is responsible for the items listed below:

1. Proper use of the appliance in accordance with instructions provided with the product.
2. Routine maintenance and cleaning necessary to keep the good working condition.
3. Proper installation by an authorized service professional in accordance with instructions provided with the appliance and in accordance with all local plumbing, electrical and / or gas codes.
4. Proper connection to a grounded power supply of sufficient voltage, replacement of blown fuses, repair of loosen connections or defects in house wiring.
5. Expenses for making the appliance accessible for servicing.
6. Damages to finish after installation.

EXCLUSIONS

This warranty does not cover the following:

- 1) Failure caused by damage to the unit while in your possession (other than damage caused by defect or malfunction), by its improper installation, or by unreasonable use of the unit, including without limitation, failure to provide reasonable and necessary maintenance or to follow the written Installation and Operating Instructions.
- 2) Damages caused by services performed by persons other than authorized Midea servicers; use of parts other than Midea replacement parts; obtained from persons other than such Midea customer service; or external causes such as abuse, misuse, inadequate power supply or acts of God.
- 3) If the unit is put to commercial, business, rental, or other use or application other than for consumer use, we make no warranties, express or implied, including but not limited to, any implied warranty of merchantability or fitness for particular use or purpose.
- 4) Products without original serial numbers or products that have serial numbers which have been altered or cannot be readily determined.

Note: Some states do not allow the exclusion or limitation of incidental or consequential damages. So this limitation or exclusion may not apply to you.

IF YOU NEED SERVICE

Keep your bill of sale, delivery slip, or some other appropriate payment record.

The date on the bill established the warranty period should service be required.

If service is performed, it is your best interest to obtain and keep all receipts.

This written warranty gives you specific legal rights. You may also have other rights that vary from state to state.

Service under this warranty must be obtained by following these steps, in order.

1. Contact Midea Consumer Services or an authorized Midea servicer at 1-866-646-4332.
2. If there is a question as to where to obtain service, contact our consumer relations Department.