

IDEALairTM

PRO SERIES

STOP

This product is precharged with refrigerant for a **25 feet** of line set.

If **MORE** than 25 feet of line set is required, refer to your Ideal-Air Service Manual for refrigerant charging chart.

For line sets between 25' & 10' in length, **REMOVE .65 oz** of R410A refrigerant per line feed.

According to manufacturer's specifications, under no circumstances should the line set be shorter than 10' in length.

If you need further assistance, please contact:

Ideal-Air Tech Support

877-943-3251

support@ideal-air.com

Service Manual

Model: IAH36LB-D3DNA3D (700478)
IAC36LB-D3DNA3D (700482)
(Refrigerant R410A)

Table of Contents

Part I : Technical Information	1
1. Summary	1
2. Specification	2
2.1 Specification Shee	2
2.2 Operation Characteristic Curve.....	8
2.3 Capacity Variation Ratio According to Temperature	8
2.4 Noise Curve.....	9
2.5 Cooling and Heating Data Sheet in Rated Frequency	9
3. Outline Dimension Diagram	10
3.1 Indoor Unit.....	10
3.2 Outdoor Unit.....	10
4. Refrigerant System Diagram	11
5. Electrical Part	13
5.1 Wiring Diagram.....	13
5.2 PCB Printed Diagram	15
6. Function and Control	17
6.1 Remote Controller Introduction	17
6.2 Brief Description of Modes and Functions.....	21
Part II : Installation and Maintenance	25
7. Notes for Installation and Maintenance	25
8. Installation	27
8.1 Installation Dimension Diagram.....	27
8.2 Installation Parts-checking	29
8.3 Selection of Installation Location.....	29
8.4 Electric Connection Requirement	29
8.5 Installation of Indoor Unit.....	29
8.6 Installation of Outdoor Unit.....	32
8.7 Vacuum Pumping and Leak Detection	33
8.8 Check after Installation and Test Operation	33

9. Troubleshooting	34
9.1 Flashing LED of Indoor/Outdoor Unit and Primary Judgement	34
9.2 How to Check Simply the Main Part	43
9.3 Troubleshooting for Normal Malfunction	59
10. Exploded View and Parts List	61
10.1 Indoor Unit	61
10.2 Outdoor Unit	64
11. Removal Procedure	68
11.1 Removal Procedure of Indoor Unit	68
11.2 Removal Procedure of Outdoor Unit	77
Appendix:	83
Appendix 1: Reference Sheet of Celsius and Fahrenheit	83
Appendix 2: Configuration of Connection Pip	83
Appendix 3: Pipe Expanding Method	84
Appendix 4: List of Resistance for Temperature Sensor	85
Warranty:	88

Part I : Technical Information

1. Summary

Indoor Unit:

IAH36LB-D3DNA3D/I
IAC36LB-D3DNA3D/I

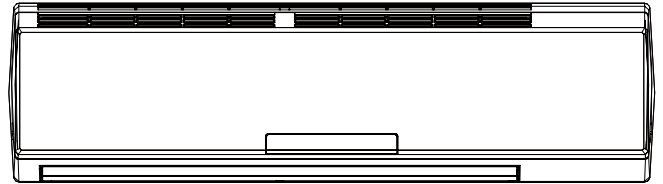

Outdoor Unit:

IAH36LB-D3DNA3D
IAC36LB-D3DNA3D

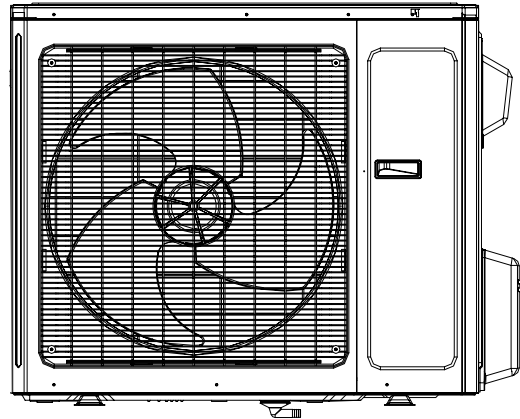

Remote Controller:

IARC-36



Model			IAC36LB-D3DNA3D	IAH36LB-D3DNA3D	
Part Number			700482	700478	
Power Supply	Rated Voltage	V~	208/230	208/230	
	Rated Frequency	Hz	60	60	
	Phases		1	1	
Power Supply Mode			Outdoor	Outdoor	
Cooling Capacity(Min~Max)		Btu/h	33600	33600	
Heating Capacity(Min~Max)		Btu/h	/	34600	
Cooling Power Input(Min~Max)		W	4100	4100	
Heating Power Input(Min~Max)		W	/	3800	
Cooling Power Current		A	17	17	
Heating Power Current		A	/	16.5	
Rated Input		W	4300	4300	
Rated Current		A	20	20	
Air Flow Volume(SH/H/M/L)		CFM	736/647/530/412	736/647/530/412	
Dehumidifying Volume		Pint/h	7.4	7.4	
EER		(Btu/h)/W	8.20	8.20	
COP		(Btu/h)/W	/	9.11	
SEER			18.00	18.00	
SCOP			/	9.00	
Application Area		yd ²	55.01-83.72	55.01-83.72	
Indoor Unit	Model of indoor unit		IAC36LB-D3DNA3D/I	IAH36LB-D3DNA3D/I	
	Fan Type		Cross-flo	Cross-flo	
	Diameter Length(DXL)		inch	Φ4 1/4X20 4/7	Φ4 1/4X20 4/7
	Fan Motor Cooling Speed (SH/H/M/L)		r/min	1400/1250/1000/800	1400/1250/1000/800
	Fan Motor Heating Speed (SH/H/M/L)		r/min	/	1400/1250/1050/850
	Output of Fan Motor		W	70	70
	Fan Motor RLA		A	0.4	0.4
	Fan Motor Capacitor		μF	/	/
	Evaporator Form			Aluminum Fin-copper Tube	Aluminum Fin-copper Tube
	Pipe Diameter		inch	Φ2/7	Φ2/7
	Row-fin Ga		inch	2-1/18	2-1/18
	Coil Length (LXDXW)		inch	42 2/7X1X15	42 2/7X1X15
	Swing Motor Model			MP24BA	MP24BA
	Output of Swing Motor		W	1.5	1.5
	Fuse		A	3.15	3.15
	Sound Pressure Level (SH/H/MH/M/ML/L/SL)		dB (A)	54/49/44/37	54/49/44/37
	Sound Power Level (SH/H/MH/M/ML/L/SL)		dB (A)	64/59/54/47	64/59/54/47
	Dimension (WXHXD)		inch	53 1/7X12 5/6X10	53 1/7X12 5/6X10
	Dimension of Carton Box (LXWXH)		inch	56 3/5X16 1/2X13 1/2	56 3/5X16 1/2X13 1/2
	Dimension of Package (LXWXH)		inch	56 3/4X16 4/7X14	56 3/4X16 4/7X14
Net Weight		lb	41.9	41.9	
Gross Weight		lb	51.8	51.8	

Outdoor Unit	Model of Outdoor Unit		IAC36LB-D3DNA3D	IAH36LB-D3DNA3D
	Part Number		700482	700478
	Compressor Manufacturer/Trademark		MITSUBISHI ELECTRIC (GUANGZHOU)COMPRESSOR CO. LTD	MITSUBISHI ELECTRIC (GUANGZHOU)COMPRESSOR CO. LTD
	Compressor Model		TNB306FPGMC	TNB306FPGMC
	Compressor Oil		FV50S	FV50S
	Compressor Type		Rotary	Rotary
	Compressor Locked Rotor Amp (L.R.A)		67.00	67.00
	Compressor RLA	A	13.50	13.50
	Compressor Power Input	W	3010	3010
	Overload Protector		CS01F272H01	CS01F272H01
	Throttling Method		Electron expansion valve	Electron expansion valve
	Operation temp	°F	61~86	61~86
	Ambient temp (cooling)	°F	0~109	0~109
	Ambient temp (heating)	°F	-4~75	-4~75
	Condenser Form		Aluminum Fin-copper Tube	Aluminum Fin-copper Tube
	Pipe Diameter	inch	Φ5/16	Φ5/16
	Rows-fin Ga	inch	2-1/18	2-1/18
	Coil Length (LXD _X W)	inch	37X1 3/4X30	37X1 3/4X30
	Fan Motor Speed	rpm	890	890
	Output of Fan Motor	W	170	170
	Fan Motor RLA	A	0.89	0.89
	Fan Motor Capacitor	μF	/	/
	Air Flow Volume of Outdoor Unit	CFM	2589	2589
	Fan Type		Axial-flo	Axial-flo
	Fan Diameter	inch	Φ21 2/3	Φ21 2/3
	Defrosting Method		Automatic Defrosting	Automatic Defrosting
	Climate Type		T1	T1
	Isolation		I	I
	Moisture Protection		IP24	IP24
	Design Pressure(High)	PSIG	550	550
	Design Pressure(Low)	PSIG	240	240
	Sound Pressure Level (H/M/L)	dB (A)	65/-/-	65/-/-
	Sound Power Level (H/M/L)	dB (A)	75/-/-	75/-/-
Dimension (WXHXD)	inch	39 1/2X31 1/9X16 4/5	39 1/2X31 1/9X16 4/5	
Dimension of Carton Box (LXWXH)	inch	42 1/2X19X33	42 1/2X19X33	
Dimension of Package (LXWXH)	inch	42 2/3X19 1/5X33 2/3	42 2/3X19 1/5X33 2/3	
Net Weight	lb	154.4	161.0	
Gross Weight	lb	165.4	172.0	
Refrigerant		R410A	R410A	
Refrigerant Charge	oz	84.66	91.71	
Connection Pipe	Length	ft	24.6	24.6
	Gas Additional Charge	oz/ft	0.2	0.5
	Outer Diameter Liquid Pipe	inch	Φ1/4	Φ1/4
	Outer Diameter Gas Pipe	inch	Φ5/8	Φ5/8
	Max Distance Height	ft	32.8	32.8
	Max Distance Length	ft	98.4	98.4
	Note:The connection pipe applies metric diameter.			

The above data is subject to change without notice; please refer to the nameplate of the unit.

2.2 Operation Characteristic Curve

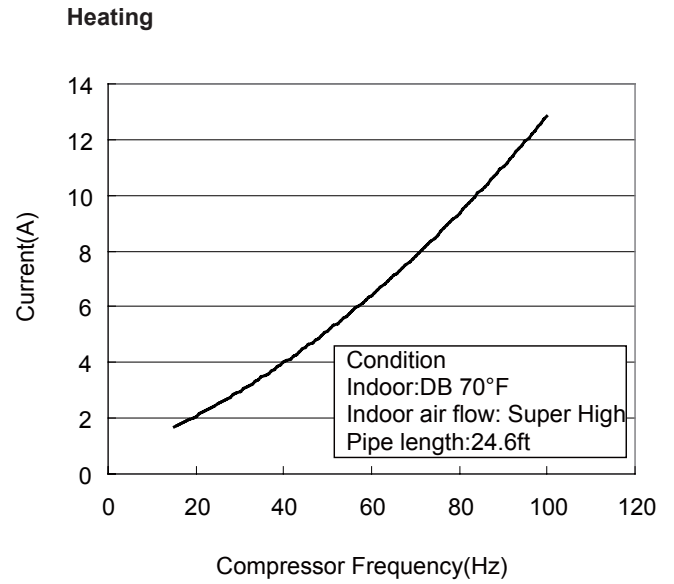
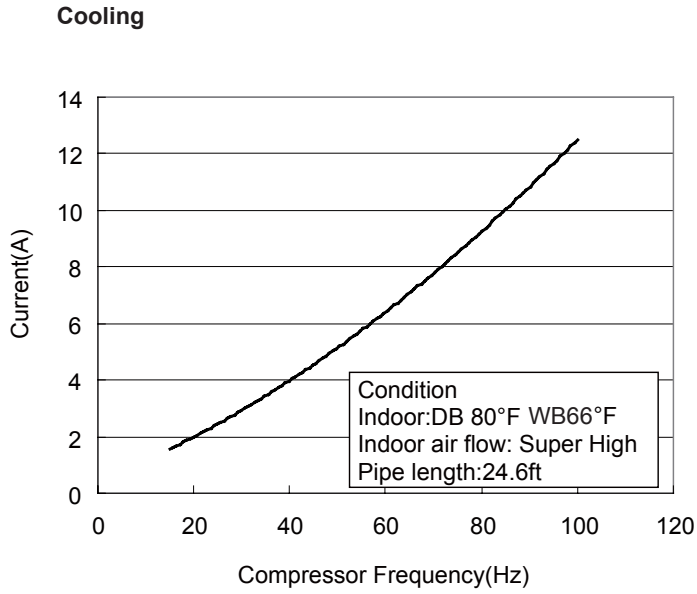

2.3 Capacity Variation Ratio According to Temperature

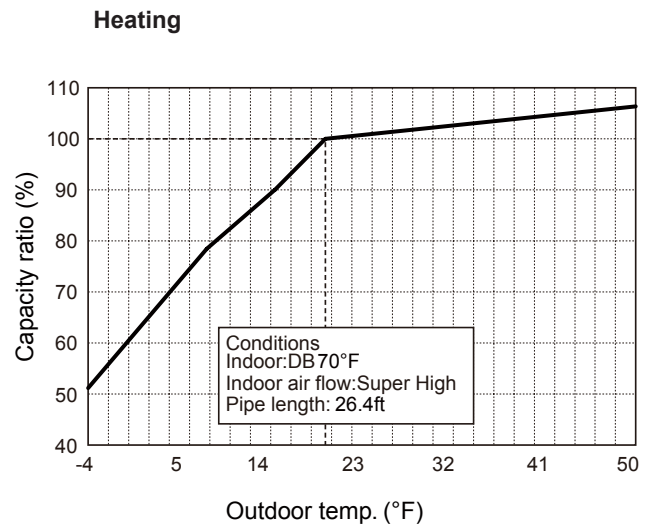
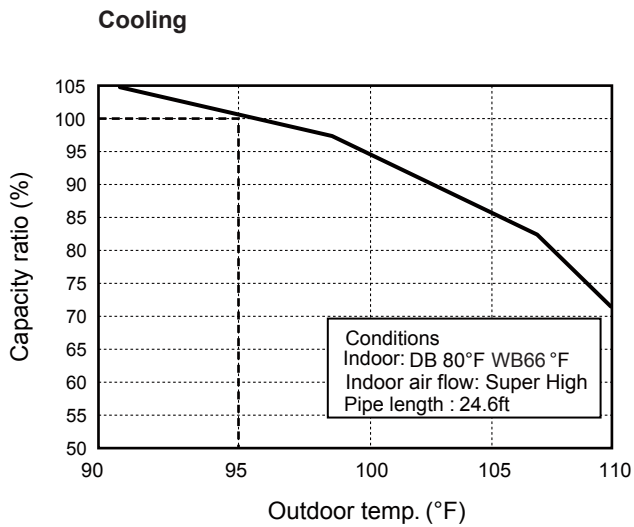

2.4 Noise Curve

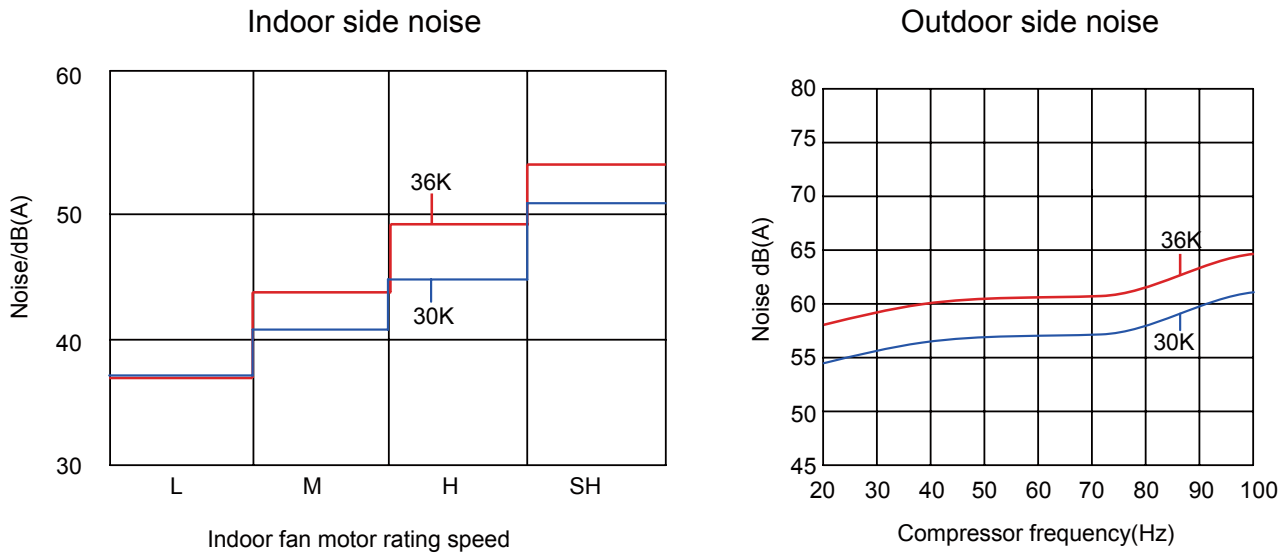

2.5 Cooling and Heating Data Sheet in Rated Frequency

Cooling:

Rated cooling condition(°F) (DB/WB)		Model	Pressure of gas pipe connecting indoor and outdoor unit	Inlet and outlet pipe temperature of heat exchanger		Fan speed of indoor unit	Fan speed of outdoor unit	Compressor revolution (rps)
Indoor	Outdoor			T1 (°F)	T2 (°F)			
80/66	95/-	30K	0.9~1.0	46.8 to 52.8	127 to 96.8	Super High	High	67
80/66	95/-	36K	0.9~1.0	46.8 to 52.8	127 to 96.8	Super High	High	60

Heating:

Rated heating condition(°F) (DB/WB)		Model	Pressure of gas pipe connecting indoor and outdoor unit	Inlet and outlet pipe temperature of heat exchanger		Fan speed of indoor unit	Fan speed of outdoor unit	Compressor revolution (rps)
Indoor	Outdoor			T1 (°F)	T2 (°F)			
70/-	20/19	30K	3.5~3.8	134.4 to 102	36 to 39	Super High	High	61
70/-	20/19	36K	3.5~3.8	134.4 to 102	36 to 39	Super High	High	58

Instruction:

T1: Inlet and outlet pipe temperature of evaporator

T2: Inlet and outlet pipe temperature of condenser

P: Pressure at the side of big valve

Connection pipe length: 24.6ft.

3. Outline Dimension Diagram

3.1 Indoor Unit

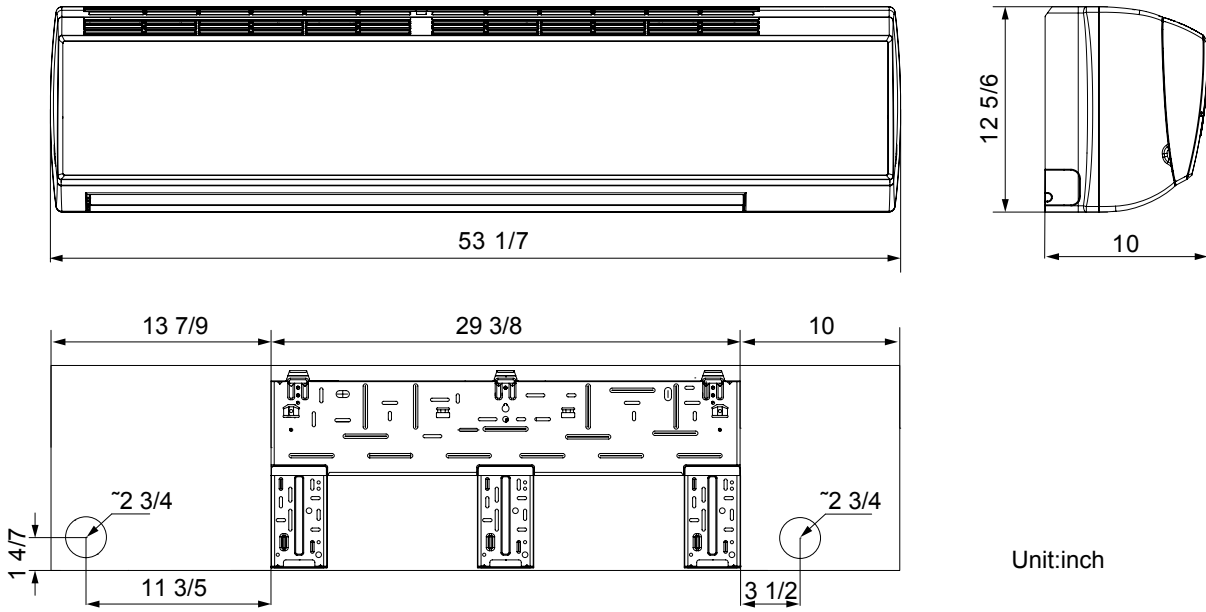

3.2 Outdoor Unit

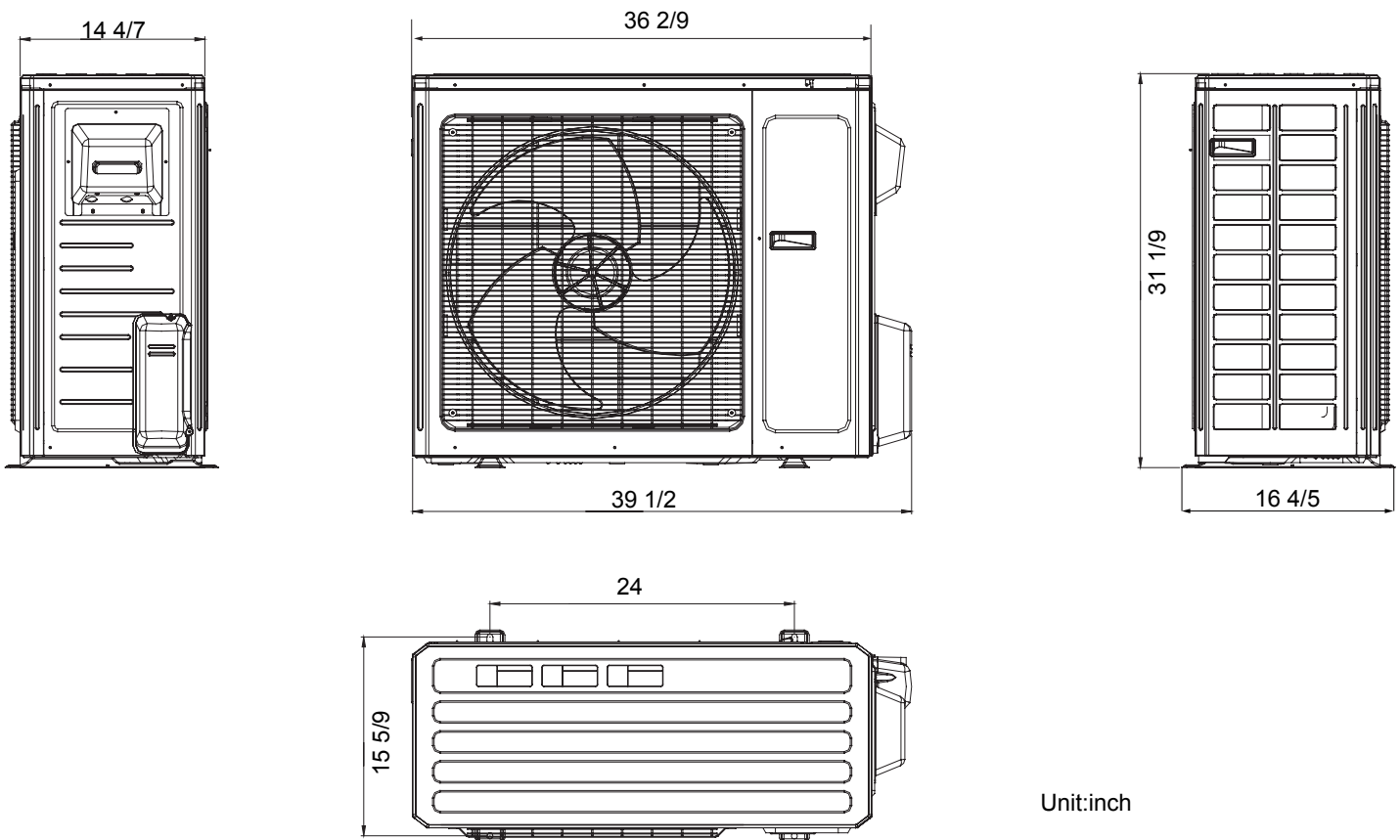

36K:



Cooling only model

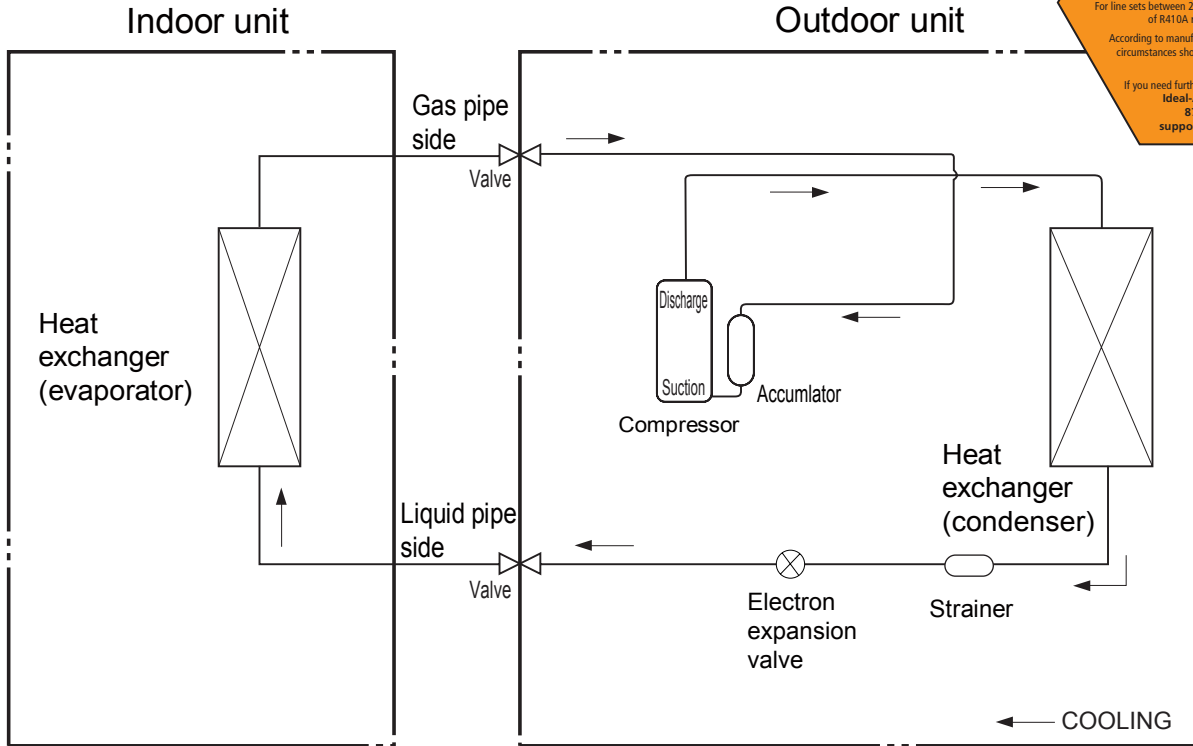

Cooling and heating model

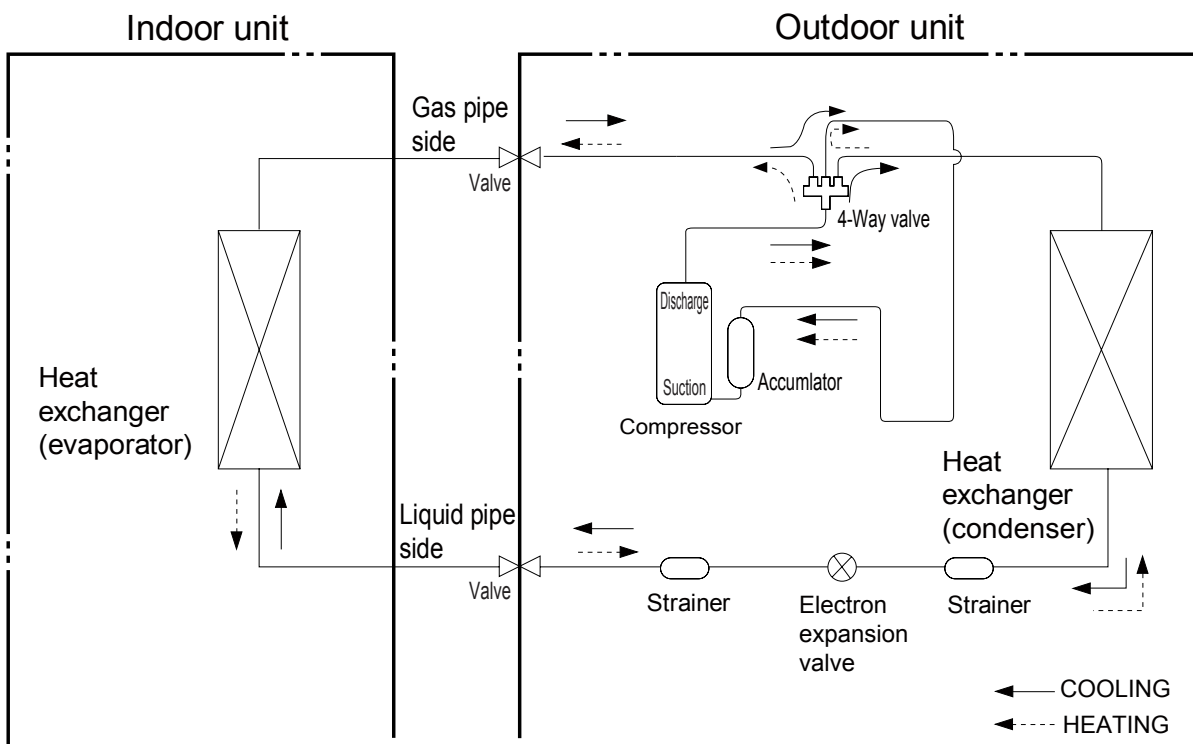

Connection pipe specification

Liquid pipe: 1/4 inch

Gas pipe: 5/8 inch

5. Electrical Part

5.1 Wiring Diagram

• Instruction

Symbol	Symbol Color	Symbol	Symbol Color	Symbol	Name
WH	White	GN	Green	CAP	Jumper cap
YE	Yellow	BN	Brown	COMP	Compressor
RD	Red	BU	Blue		Grounding wire
YEGN	Yellow/Green	BK	Black	/	/
VT	Violet	OG	Orange	/	/

Note: Jumper cap is used to determine fan speed and the swing angle of horizontal lover for this model.

• Indoor Unit

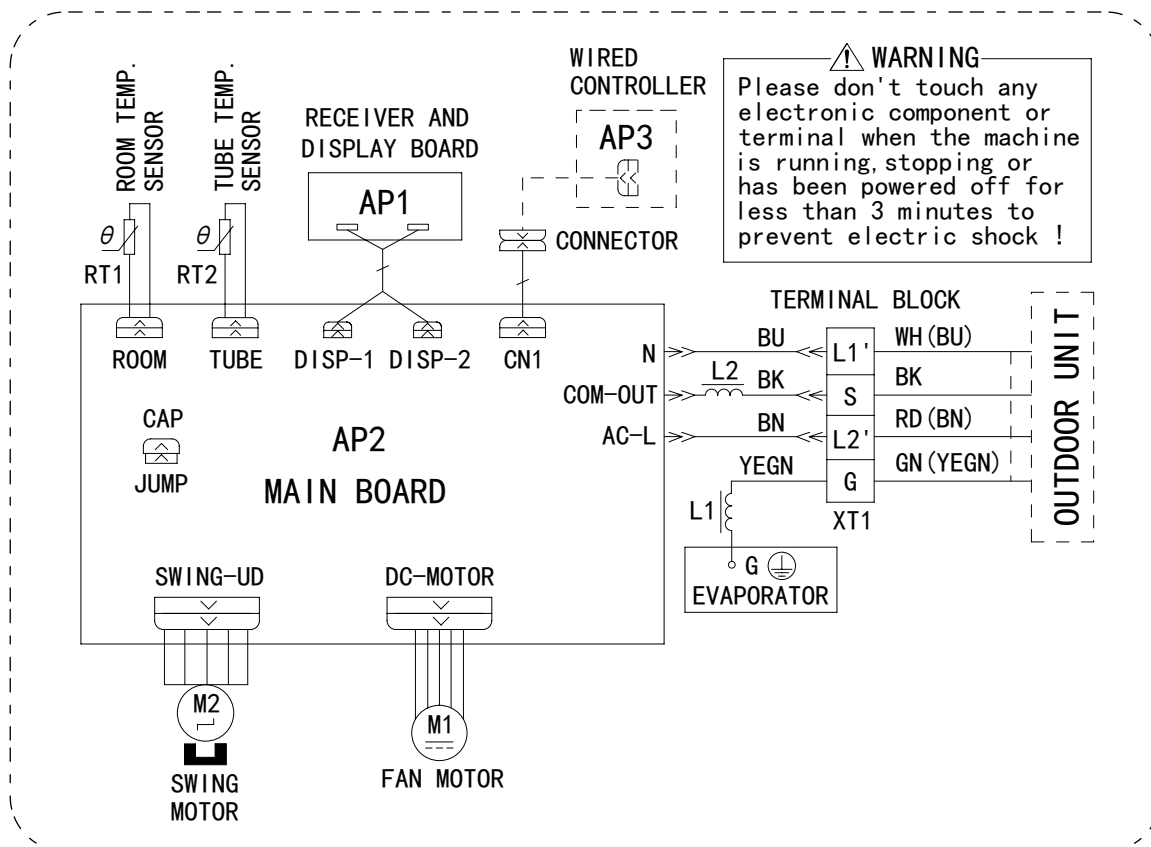

● Outdoor Unit

IAC36LB-D3DNA3D

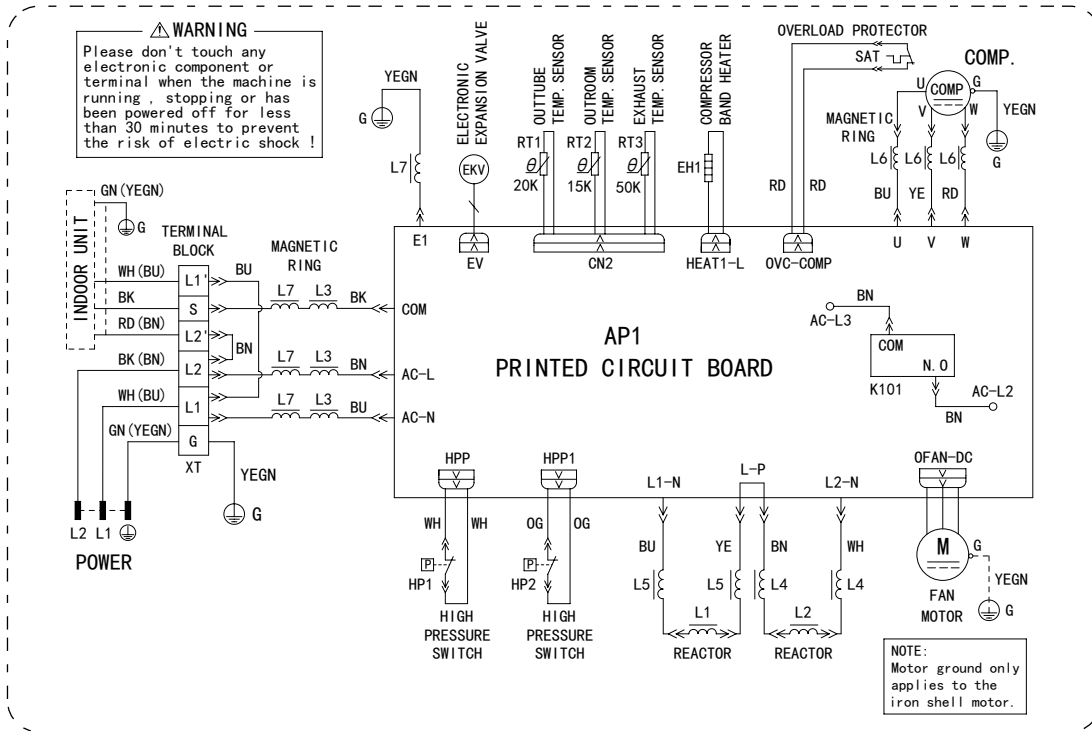

IAWH36LB-D3DNA3D

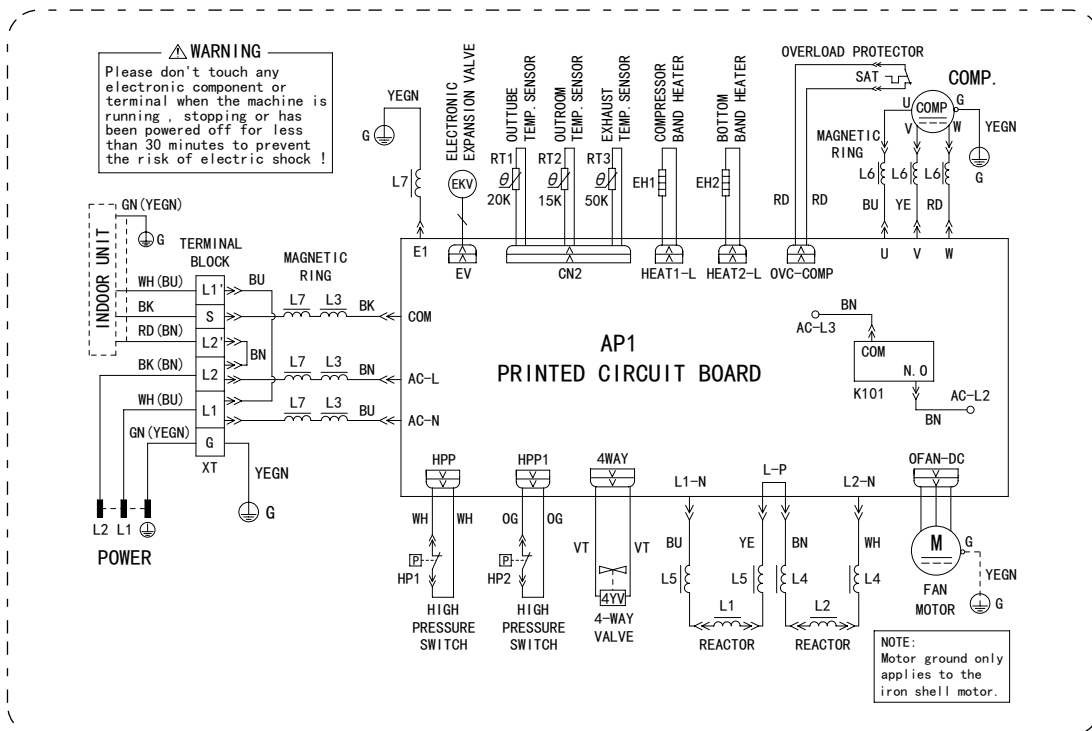

The above data is subject to change without notice. Please refer to the nameplate of the unit.

5.2 PCB Printed Diagram

Indoor Unit

• Top view

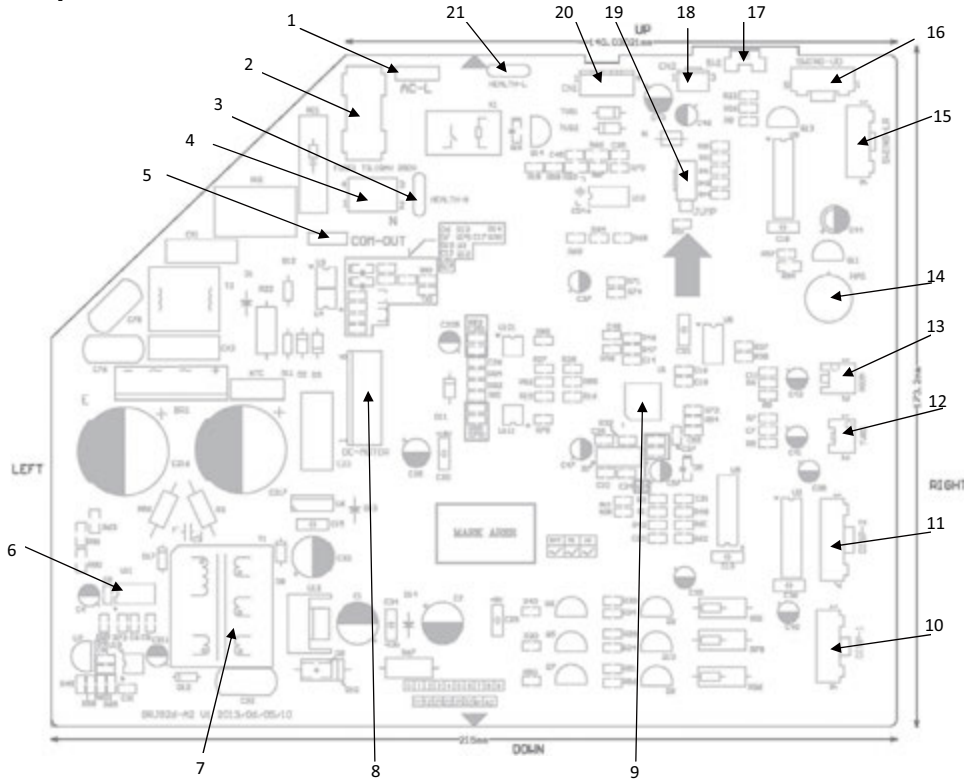

No.	Name
1	Power supply live wire
2	Fuse
3	Interface of neutral wire for health function
4	Power supply neutral wire
5	Interface of communication
6	Power switch
7	High-frequency transformer
8	Interface of fan motor
9	Buzzer
10	Interface of display
11	Interface of display
12	Indoor tube temperature sensor interface
13	Ambient temperature sensor interface
14	Interface of wired controller
15	Interface of left and right swing terminal
16	Interface of up and down swing terminal
17	Auto button
18	Interface of BMS
19	Jumper cap
20	Interface of wired controller
21	Interface of live wire for health function

• Bottom view

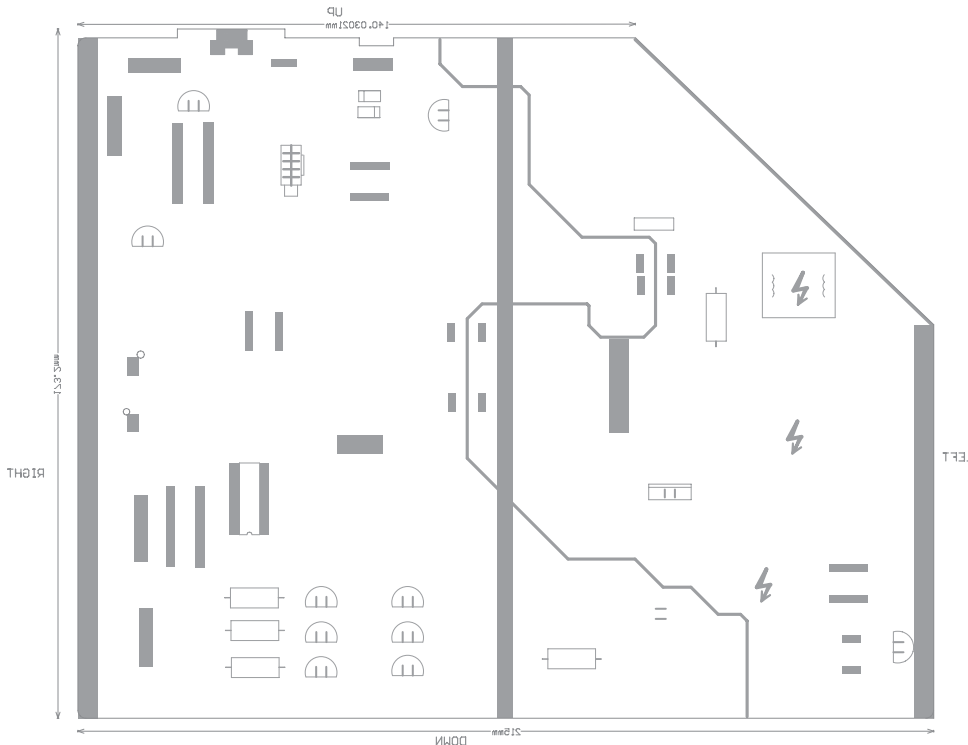

Outdoor Unit

• Top view

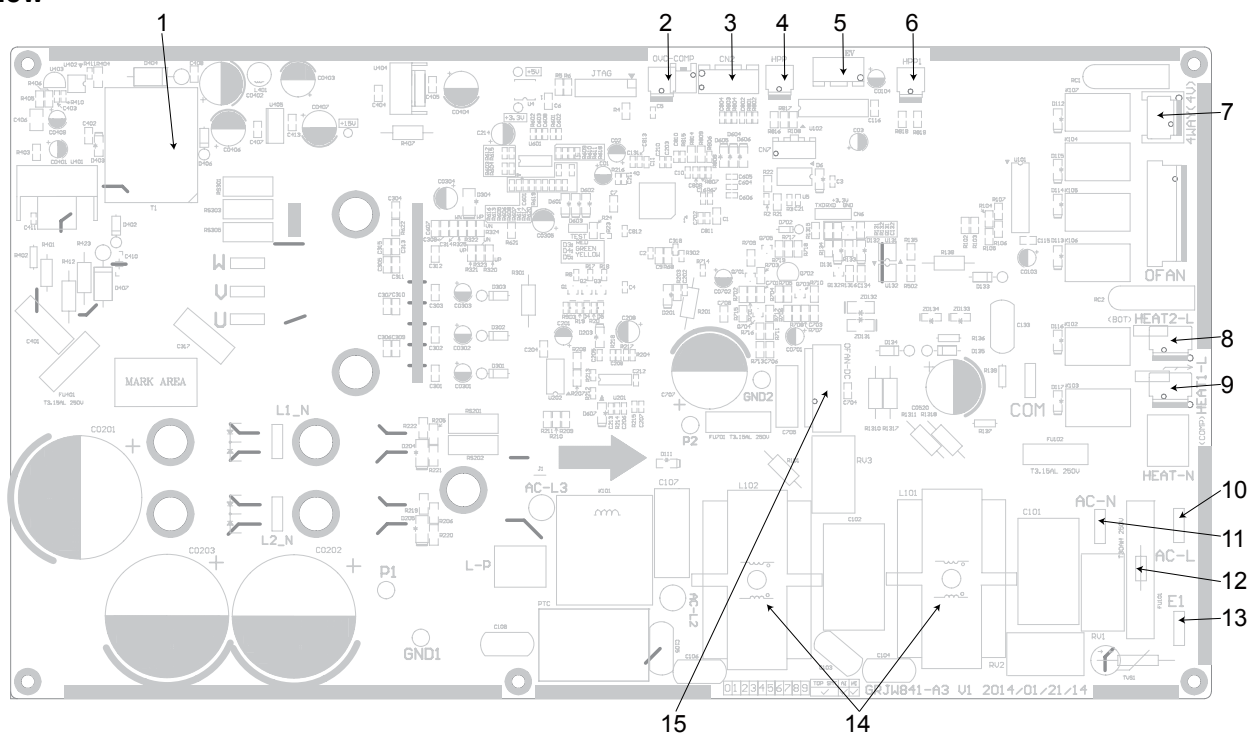

No.	Name	No.	Name	No.	Name
1	High-frequency transformer T1	6	High pressure protection terminal HPP1	11	Terminal of neutral wire
2	Overload protection terminal of compressor OVC-COMP	7	Terminal of 4-way valve	12	Protective tube FU101
3	Terminal of temp sensor CN2	8	Electric heater band of chassis HEAT2-L	13	Terminal of ground wire
4	High pressure protection terminal HPP	9	Electric heater band of compressor HEAT1-L	14	Choke L 101 and L 102
5	Electronic expansion valve terminal EV	10	Terminal of live wire	15	Terminal of outdoor fan OFAN-DC

• Bottom view

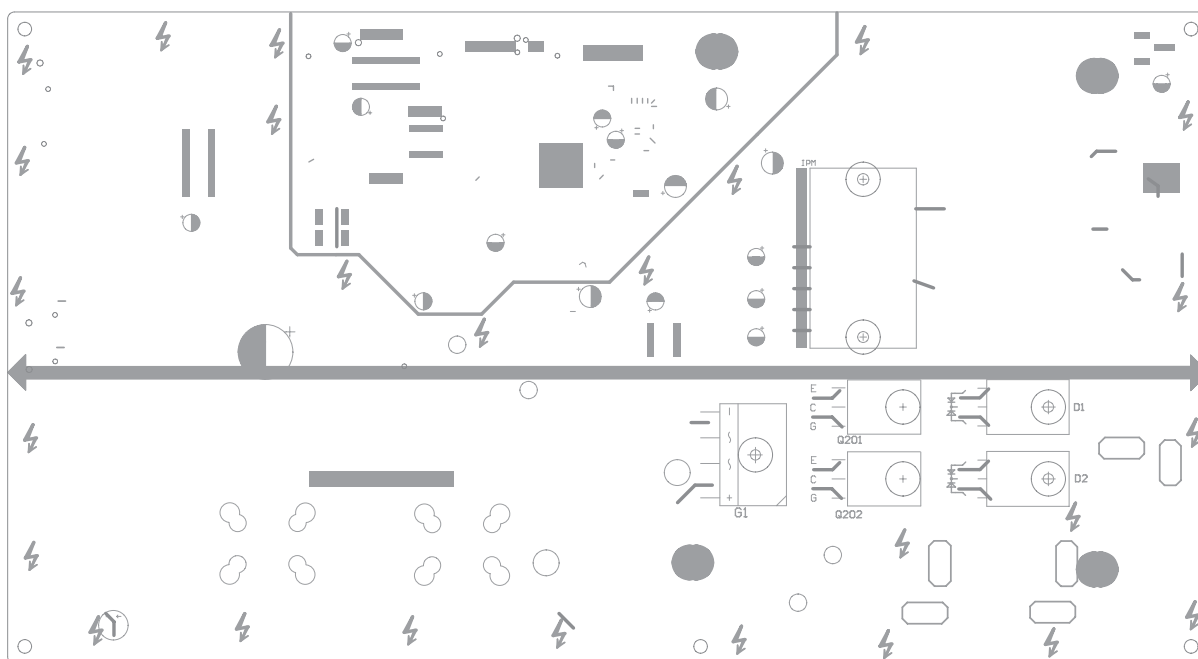

6. Function and Control

6.1 Remote Controller Introduction



- 1 ON/OFF button
- 2 MODE button
- 3 FAN button
- 4 SWING button
- 5 TURBO button
- 6 ▲/ ▼button
- 7 SLEEP button
- 8 TEMP button
- 9 I FEEL button
- 10 LIGHT button
- 11 CLOCK button
- 12 TIMER ON / TIMER OFF button

Introduction for icons on display screen

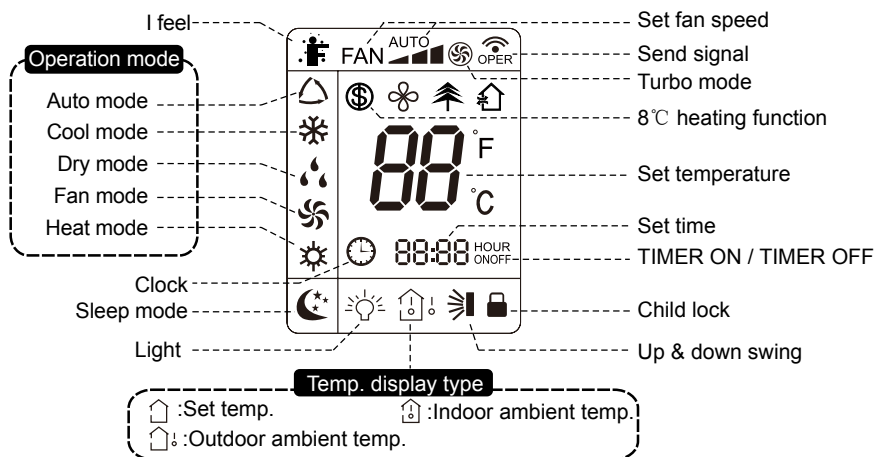

Introduction for buttons on remote controller

Note:

- After putting through the power, the air conditioner will give out a sound. Operation indicator "⏻" is ON (red indicator). After that, you can operate the air conditioner by using remote controller.
- Under on status, pressing the button on the remote controller, the signal icon "📶" on the display of remote controller will blink once and the air conditioner will give out a "de" sound, which means the signal has been sent to the air conditioner.
- Under off status, set temperature and clock icon will be displayed on the display of remote controller (If timer on, timer off and light functions are set, the corresponding icons will be displayed on the display of remote controller at the same time); Under on status, the display will show the corresponding set function icons.

1. ON/OFF button

Press this button can turn on or turn off the air conditioner. After turning on the air conditioner, operation indicator "⏻" on indoor unit's display is ON (green indicator. The colour is different for different models), and indoor unit will give out a sound.

2. MODE button

Press this button to select your required operation mode.

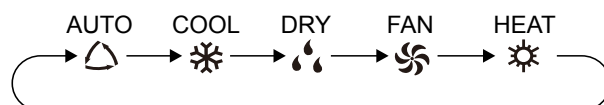

- When selecting auto mode, air conditioner will operate automatically according to ex-factory setting. Set temperature can't be adjusted and will not be displayed as well. Press "FAN" button can adjust fan speed. Press "SWING" button can adjust fan blowing angle.
- After selecting cool mode, air conditioner will operate under cool mode. Cool indicator "❄️" on indoor unit is ON. Press "▲" or "▼" button to adjust set temperature. Press "FAN" button to adjust fan speed. Press "SWING" button to adjust fan blowing angle.
- When selecting dry mode, the air conditioner operates at low speed under dry mode. Dry indicator "💧" on indoor unit is ON. Under dry mode, fan speed can't be adjusted. Press "SWING" button to adjust fan blowing angle.
- When selecting fan mode, the air conditioner will only blow fan, no cooling and no heating. All indicators are OFF. Press "FAN" button to adjust fan speed. Press "SWING" button to adjust fan blowing angle.
- When selecting heating mode, the air conditioner operates under heat mode. Heat indicator "☀️" on indoor unit is ON. Press "▲" or "▼" button to adjust set temperature. Press "FAN" button to adjust fan speed. Press "SWING" button to adjust fan blowing angle. (Cooling only unit won't receive heating mode signal. If setting heat mode with remote controller, press ON/OFF button can't start up the unit).

Note:

- For preventing cold air, after starting up heating mode, indoor unit will delay 1~5 minutes to blow air (actual delay time is depend on indoor ambient temperature).
- Set temperature range from remote controller: 16~30°C (60.8~86.0°F); Fan speed: auto, low speed, medium speed, high speed.

3. FAN button

Pressing this button can set fan speed circularly as: auto (AUTO), low(▲), medium(▲▲), high(▲▲▲).

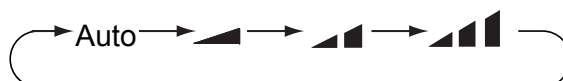

Caution:

- Under AUTO speed, air conditioner will select proper fan speed automatically according to ex-factory setting.
- Fan speed under dry mode is low speed.

4. SWING button

Press this button can select up&down swing angle. Fan blow angle can be selected circularly as below:

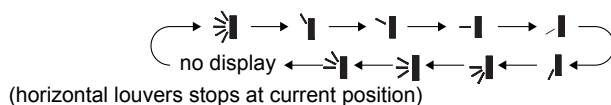

- When selecting "☞", air conditioner is blowing fan automatically. Horizontal louver will automatically swing up & down at maximum angle.
- When selecting "┆", "┆", "┆", "┆", "┆", air conditioner is blowing fan at fixed position. Horizontal louver will stop at the fixed position.
- When selecting "☞", "☞", "☞", "☞", air conditioner is blowing fan at fixed angle. Horizontal louver will send air at the fixed angle.
- Hold "☞" button above 2s to set your required swing angle. When reaching your required angle, release the button.

Note:

- "☞", "☞", "☞" may not be available. When air conditioner receives this signal, the air conditioner will blow fan automatically.

5. TURBO button

Under COOL or HEAT mode, press this button to turn to quick COOL or quick HEAT mode. "⚡" icon is displayed on remote controller. Press this button again to exit turbo function and "⚡" icon will disappear.

6. ▲/▼ button

- Press "▲" or "▼" button once increase or decrease set temperature 1°C (33.8°F). Holding "▲" or "▼" button, 2s later, set temperature on remote controller will change quickly. On releasing button after setting is finished, temperature indicator on indoor unit will change accordingly. (Temperature can't be adjusted under auto mode)
- When setting TIMER ON, TIMER OFF or CLOCK, press "▲" or "▲" button to adjust time. (Refer to CLOCK, TIMER ON, TIMER OFF buttons) When setting TIMER ON, TIMER OFF or CLOCK, press "▲" or "▲" button to adjust time. (Refer to CLOCK, TIMER ON, TIMER OFF buttons)

7. SLEEP button

Under COOL, HEAT or DRY mode, press this button to start up sleep function. "☾" icon is displayed on remote controller. Press this button again to cancel sleep function and "☾" icon will disappear.

8. TEMP button

By pressing this button, you can see indoor set temperature, indoor ambient temperature or outdoor ambient temperature on indoor unit's display. The setting on remote controller is selected circularly as below:

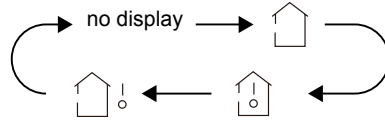

- When selecting "House Icon" or no display with remote controller, temperature indicator on indoor unit displays set temperature.
- When selecting "House Icon with Thermometer" with remote controller, temperature indicator on indoor unit displays indoor ambient temperature.
- When selecting "House Icon with Thermometer and Exclamation Mark" with remote controller, temperature indicator on indoor unit displays outdoor ambient temperature.

Note:

- Outdoor temperature display is not available for some models. At that time, indoor unit receives "House Icon with Exclamation Mark" signal, while it displays indoor set temperature.
- It's defaulted to display set temperature when turning on the unit. There is no display in the remote controller.
- Only for the models whose indoor unit has dual-8 display.
- When selecting displaying of indoor or outdoor ambient temperature, indoor temperature indicator displays corresponding temperature and automatically turn to display set temperature after three or five seconds

9. I FEEL button

Press this button to start I FEEL function and "I FEEL" icon will be displayed on the remote controller. After this function is set, the remote controller will send the detected ambient temperature to the controller and the unit will automatically adjust the indoor temperature according to the detected temperature. Press this button again to close I FEEL function and "I FEEL" icon will disappear.

- Please put the remote controller near user when this function is set. Do not put the remote controller near the object of high temperature or low temperature in order to avoid detecting inaccurate ambient temperature.

10. LIGHT button

Press this button to turn off display light on indoor unit. "Light Off" icon on remote controller disappears. Press this button again to turn on display light. "Light On" icon is displayed.

11. CLOCK button

Press this button to set clock time. "Clock" icon on remote controller will blink. Press "▲" or "▼" button within 5s to set clock time. Each pressing of "▲" or "▼" button, clock time will increase or decrease 1 minute. If hold "▲" or "▼" button, 2s later, time will change quickly. Release this button when reaching your required time. Press "CLOCK" button to confirm the time. "Clock" icon stops blinking.

Note:

- Clock time adopts 24-hour mode.
- The interval between two operation can't exceeds 5s. Otherwise, remote controller will quit setting status. Operation for TIMER ON/TIMER OFF is the same.

12. TIMER ON / TIMER OFF button

• TIMER ON button

"TIMER ON" button can set the time for timer on. After pressing this button, "Clock" icon disappears and the word "ON" on remote controller blinks. Press "▲" or "▼" button to adjust TIMER ON setting. After each pressing "▲" or "▼" button, TIMER ON setting will increase or decrease 1min. Hold "▲" or "▼" button, 2s later, the time will change quickly until reaching your required time. Press "TIMER ON" to confirm it. The word "ON" will stop blinking. "Clock" icon resumes displaying. Cancel TIMER ON: Under the condition that TIMER ON is started up, press "TIMER ON" button to cancel it.

• TIMER OFF button

"TIMER OFF" button can set the time for timer off. After pressing this button, "Clock" icon disappears and the word "OFF" on remote controller blinks. Press "▲" or "▼" button to adjust TIMER OFF setting. After each pressing "▲" or "▼" button, TIMER OFF setting will increase or decrease 1min. Hold "▲" or "▼" button, 2s later, the time will change quickly until reaching your required time. Press "TIMER OFF" word "OFF" will stop blinking. "Clock" icon resumes displaying. Cancel TIMER OFF. Under the condition that TIMER OFF is started up, press "TIMER OFF" button to cancel it.

Note:

- Under on and off status, you can set TIMER OFF or TIMER ON simultaneously.
- Before setting TIMER ON or TIMER OFF, please adjust the clock time.
- After starting up TIMER ON or TIMER OFF, set the constant circulating valid. After that, air conditioner will be turned on or turned off according to setting time. ON/OFF button has no effect on setting. If you don't need this function, please use remote controller to cancel it.

Function introduction for combination buttons

1. Energy-saving function

Under cooling mode, press "TEMP" and "CLOCK" buttons simultaneously to start up or turn off energy-saving function. When energy-saving function is started up, "SE" will be shown on remote controller, and air conditioner will adjust the set temperature automatically according to ex-factory setting to reach to the best energy-saving effect. Press "TEMP" and "CLOCK" buttons simultaneously again to exit energy-saving function.

Note:

- Under energy-saving function, fan speed is defaulted at auto speed and it can't be adjusted.
- Under energy-saving function, set temperature can't be adjusted. Press "TURBO" button and the remote controller won't send signal.
- Sleep function and energy-saving function can't operate at the same time. If energy-saving function has been set under cooling mode, press sleep button will cancel energy-saving function. If sleep function has been set under cooling mode, start up the energy-saving function will cancel sleep function.

2. 8 °C heating function

Under heating mode, press "TEMP" and "CLOCK" buttons simultaneously to start up or turn off 8 °C heating function. When this function is started up, "⊕" and "8°C" will be shown on remote controller, and the air conditioner keep the heating status at 8 °C. Press "TEMP" and "CLOCK" buttons simultaneously again to exit 8 °C heating function.

Note:

- Under 8 °C heating function, fan speed is defaulted at auto speed and it can't be adjusted.
- Under 8 °C heating function, set temperature can't be adjusted. Press "TURBO" button and the remote controller won't send signal.
- Sleep function and 8 °C heating function can't operate at the same time. If 8 °C heating function has been set under cooling mode, press sleep button will cancel 8 °C heating function. If sleep function has been set under cooling mode, start up the 8 °C heating function will cancel sleep function.
- Under °F temperature display, the remote controller will display 46 °F heating.

3. Child lock function

Press "▲" and "▼" simultaneously to turn on or turn off child lock function. When child lock function is on, "🔒" icon is displayed on remote controller. If you operate the remote controller, the "🔒" icon will blink three times without sending signal to the unit.

4. Temperature display switchover function

Under OFF status, press "▼" and "MODE" buttons simultaneously to switch temperature display between °C and °F.

Operation guide

1. After putting through the power, press "ON/OFF" button on remote controller to turn on the air conditioner.
2. Press "MODE" button to select your required mode: AUTO, COOL, DRY, FAN, HEAT.
3. Press "▲" or "▼" button to set your required temperature. (Temperature can't be adjusted under auto mode).
4. Press "FAN" button to set your required fan speed: auto, low, medium and high speed.
5. Press "SWING" button to select fan blowing angle.

Replacement of batteries in remote controller

1. Press the back side of remote controller marked with "🔓", as shown in the fig, and then push out the cover of battery box along the arrow direction.
2. Replace two 7# (AAA 1.5V) dry batteries, and make sure the position of "+" polar and "-" polar are correct.
3. Reinstall the cover of battery box.

Note:

- During operation, point the remote control signal sender at the receiving window on indoor unit.
- The distance between signal sender and receiving window should be no more than 8m, and there should be no obstacles between them.
- Signal may be interfered easily in the room where there is fluorescent lamp or wireless telephone; remote controller should be close to indoor unit during operation.
- Replace new batteries of the same model when replacement is required.
- When you don't use remote controller for a long time, please take out the batteries.
- If the display on remote controller is fuzzy or there's no display, please replace batteries.

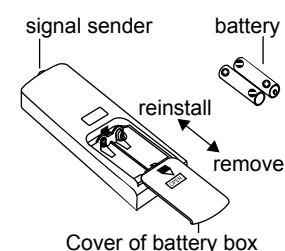

6.2 Brief Description of Modes and Functions

1. Temperature Parameters

- ◆ Indoor preset temperature (T_{preset})
- ◆ Indoor ambient temperature ($T_{\text{amb.}}$)

2. Basic Functions

Once energized, in no case should the compressor be restarted within less than 3 minutes. In the situation that memory function is available, for the first energization, if the compressor is at stop before de-energization, the compressor will be started without a 3-minute lag; if the compressor is in operation before de-energization, the compressor will be started with a 3-minute lag; and once started, the compressor will not be stopped within 6 minutes regardless of changes in room temperature;

(1) Cooling Mode

① Working conditions and process of cooling

When $T_{\text{amb}} \leq T_{\text{preset}}$, the unit will enter cooling operation, in which case the indoor fan, the outdoor fan and the compressor will work and the indoor fan will run at preset speed.

When $T_{\text{amb}} \sim T_{\text{preset}} - 3.6^\circ\text{F}$, the compressor will stop, the outdoor fan will stop with a time lag of 60s, and the indoor fan will run at preset speed.

When $T_{\text{preset}} - 3.6^\circ\text{F} < T_{\text{amb.}} < T_{\text{preset}} + 1.8^\circ\text{F}$, the unit will remain at its previous state.

➤ Under this mode, the four-way valve will be de-energized and temperature can be set within a range from 61 to 86°F. If the compressor is shut down for some reason, the indoor fan and the swing device will operate at original state.

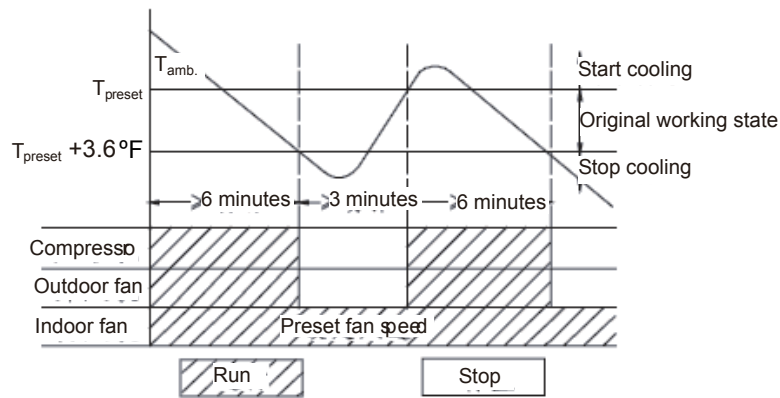

② Protection

◆ Antifreeze protection

Under cooling and dehumidifying mode, 6 minutes after the compressor is started:

If $T_{\text{evap}} \sim 35.6^\circ\text{F}$, the compressor will operate at reduced frequency.

If $T_{\text{evap}} \sim 30.2^\circ\text{F}$ is detected for durative 3 minutes, the compressor will stop, and after 60 seconds, the outdoor fan will stop; and under cooling mode, the indoor fan and the swing motor will remain at the original state.

If $T_{\text{evap}} \leq 42.8^\circ\text{F}$ and the compressor has remained at OFF for at least 3 minutes, the compressor will resume its original operation state.

◆ Total current up and frequency down protection

If $I_{\text{total}} \sim 16\text{A}$, frequency rise will be allowed; if $I_{\text{total}} \leq 17\text{A}$, frequency rise will not be allowed; if $I_{\text{total}} \geq 18\text{A}$, the compressor will run at reduced frequency; and if $I_{\text{total}} \leq 20\text{A}$, the compressor will stop and the outdoor fan will stop with a time lag of 60s.

(2) Dehumidifying Mode

① Working conditions and process of dehumidifying

If $T_{\text{amb}} > T_{\text{preset}} + 1.8^\circ\text{F}$, the unit will enter cooling and dehumidifying mode, in which case the compressor and the outdoor fan will operate and the indoor fan will run at low speed.

If $T_{\text{preset}} - 3.6^\circ\text{F} \sim T_{\text{amb}} \sim T_{\text{preset}} + 1.8^\circ\text{F}$, the compressor remains at its original operation state.

If $T_{\text{amb.}} < T_{\text{preset}} - 3.6^\circ\text{F}$, the compressor will stop, the outdoor fan will stop with a time lag of 60s, and the indoor fan will operate at low speed.

② Protection

Protection is the same as that under the cooling mode.

(3) Heating Mode

① Working conditions and process of heating

If $T_{\text{amb.}} \circ T_{\text{preset}} + 3.6^{\circ}\text{F}$, the unit enters heating mode, in which case the four-way valve, the compressor and the outdoor fan will operate simultaneously, and the indoor fan will run at preset speed in the condition of preset cold air prevention.

If $T_{\text{amb.}} \sim T_{\text{preset}} + 9^{\circ}\text{F}$, the compressor will stop, the outdoor fan will stop with a time lag of 60s, and the indoor fan will stop after 60-second blow at low speed

If $T_{\text{preset}} + 3.6^{\circ}\text{F} < T_{\text{amb.}} < T_{\text{preset}} + 9^{\circ}\text{F}$, the unit will maintain its original operating status.

➤ Under this mode, the four-way valve is energized and temperature can be set within a range of 61 - 86°F. The operating symbol, the heating symbol and preset temperature are revealed on the display.

② Condition and process of defrost

When duration of successive heating operation is more than 45 minutes, or accumulated heating time more than 90 minutes, and one of the following conditions is reached, the unit will enter the defrost mode after 3 minutes.

A $T_{\text{outdoor amb.}} \sim 41^{\circ}\text{F}$, $T_{\text{outdoor pipe}} \circ 28.4^{\circ}\text{F}$;

B $28.4^{\circ}\text{F} \circ T_{\text{outdoor amb.}}$

C $23^{\circ}\text{F} \circ T_{\text{outdoor amb.}} < 28.4^{\circ}\text{F}$, $T_{\text{outdoor pipe}} \circ 17.6^{\circ}\text{F}$;

D $14^{\circ}\text{F} \circ T_{\text{outdoor amb.}} < 23^{\circ}\text{F}$, $T_{\text{outdoor pipe}} - T_{\text{compensation}} \circ (T_{\text{outdoor amb.}} - 5.4^{\circ}\text{F})$;

E $T_{\text{outdoor amb.}} < 14^{\circ}\text{F}$, $T_{\text{outdoor pipe}} - T_{\text{compensation}} \circ (T_{\text{outdoor amb.}} - 5.4^{\circ}\text{F})$

After energization, when defrosting for the first time $T_{\text{compensation}} = 0^{\circ}\text{F}$. If it is not the firstly time for defrosting, the $T_{\text{compensation}}$ is determined by the $T_{\text{outdoor pipe}}$ of last time quitting defrosting.

a. $T_{\text{outdoor pipe}} > 35.6^{\circ}\text{F}$, $T_{\text{compensation}} = 0^{\circ}\text{F}$; b. $T_{\text{outdoor pipe}} \circ 35.6^{\circ}\text{F}$, $T_{\text{compensation}} = 5.4^{\circ}\text{F}$

At that time, the indoor fan stops and the compressor stops, and after 60 seconds the outer fan will stop, and then after 30 seconds, the four-way valve will stop. After 30 seconds, the compressor is initiated for raising the frequency to defrost frequency.

When the compressor has operated under defrost mode for 10 minutes, or $T_{\text{outer tube}} \geq 50^{\circ}\text{F}$, the compressor will be converted to 46Hz operation. After 30 seconds, the compressor will stop. And after another 30 seconds, the four-way valve will be opened, and after 60 seconds, the compressor and the outer fan will be started, the indoor fan will run under preset cold air prevention conditions, and H1 will be displayed at temperature display area on the display panel. Defrost frequency is 70Hz.

3. Protection

◆ Cold air prevention

The unit is started under heating mode (the compressor is ON):

① In the case of $T_{\text{indoor amb.}} < 75^{\circ}\text{F}$: if $T_{\text{tube}} \circ 104^{\circ}\text{F}$ and the indoor fan is at stop state, the indoor fan will begin to run at low speed with a time lag of 2 minutes. Within 2 minutes, if $T_{\text{tube}} > 104^{\circ}\text{F}$, the indoor fan also will run at low speed; and after 1-minute operation at low speed, the indoor fan will be converted to operation at preset speed. Within 1-minute low speed operation or 2-minute non-operation, if $T_{\text{tube}} > 108^{\circ}\text{F}$, the fan will run at present speed.

② In the case of $T_{\text{indoor amb.}} \sim 75^{\circ}\text{F}$: if $T_{\text{tube}} \circ 108^{\circ}\text{F}$, the indoor fan will run at low speed, and after one minute, the indoor fan will be converted to preset speed. Within one-minute low speed operation, if $T_{\text{tube}} > 104^{\circ}\text{F}$, the indoor fan will be converted to preset speed.

Note: $T_{\text{indoor amb.}}$ indicated in ① and ② refers to, under initially heating mode, the indoor ambient temperature before the command to start the compressor is performed according to the program, or after the unit is withdrawn from defrost, the indoor ambient temperature before the defrost symbol is cleared.

◆ Total current up and frequency down protection

If the total current $I_{\text{total}} \circ 16\text{A}$, frequency rise will be allowed; if $I_{\text{total}} \sim 17\text{A}$, frequency rise will not be allowed; if $I_{\text{total}} \sim 18\text{A}$, the compressor will run at reduced frequency; and if $I_{\text{total}} \sim 20\text{A}$, the compressor will stop and the outdoor fan will stop with a time lag of 60s.

(4) Fan Mode

Under the mode, the indoor fan will run at preset speed and the compressor, the outdoor fan, the four-way valve and the electric heater will stop.

➤ Under the mode, temperature can be set within a range of 61 - 86°F.

(5) AUTO Mode

① Working conditions and process of AUTO mode

Under AUTO mode, standard cooling temperature T_{preset} is 77°F and standard heating temperature T_{preset} is 68°F .

a. Once energized, if $T_{\text{amb.}} \circ 71.6^{\circ}\text{F}$, the unit will be started under heating mode; if $71.6^{\circ}\text{F} < T_{\text{amb.}} < 78.8^{\circ}\text{F}$, the unit will run under fan mode and the run indicator will be bright; and if $T_{\text{amb.}} \sim 78.8^{\circ}\text{F}$, the unit will be started under cooling mode.

b. Under AUTO mode, if $T_{amb.} \geq T_{preset} + 1.8^{\circ}\text{F}$ is detected, the unit will select to run under cooling mode, in which case implicit preset temperature is 77°F ; if $T_{amb.} \sim T_{preset} - 1.8^{\circ}\text{F}$, the compressor will stop, the outdoor fan will stop with a time lag of 1 minute, and the indoor fan will run at preset speed; and if $T_{preset} - 1.8^{\circ}\text{F} < T_{amb.} < T_{preset} + 1.8^{\circ}\text{F}$, the unit will remain at its original state.

c. Under AUTO mode, if $T_{amb.} \sim T_{preset} + 3.6^{\circ}\text{F}$ is detected, the unit will select to run under heating mode, in which case implicit preset temperature is 64°F ; if $T_{amb.} \geq T_{preset} + 9^{\circ}\text{F}$, the compressor will stop, the outdoor fan will stop with a time lag of 1 minute, and the indoor fan will run under the mode of residue heat blowing; and if $T_{preset} + 3.6^{\circ}\text{F} < T_{amb.} < T_{preset} + 41^{\circ}\text{F}$, the unit will remain at its original state. The cooling-only unit will run under fan mode.

d. Under AUTO mode, if $71.6^{\circ}\text{F} < T_{amb.} < 78.8^{\circ}\text{F}$, the unit will remain at its original state.

② Protection

a. In cooling operation, protection is the same as that under the cooling mode;

b. In heating operation, protection is the same as that under the heating mode;

c. When ambient temperature changes, operation mode will be converted preferentially. Once started, the compressor will remain unchanged for at least 6 minutes.

(6) Common Protection Functions and Fault Display under COOL, HEAT, DRY and AUTO Modes

① Overload protection

T_{tube} : measured temperature of outdoor heat exchanger under cooling mode; and measured temperature of indoor heat exchanger under heating mode.

1) Cooling overload

a. If $T_{tube} \sim 126^{\circ}\text{F}$, the unit will return to its original operation state.

b. If $T_{tube} \geq 131^{\circ}\text{F}$, frequency rise is not allowed.

c. If $T_{tube} \geq 136^{\circ}\text{F}$, the compressor will run at reduced frequency.

d. If $T_{tube} \geq 144^{\circ}\text{F}$, the compressor will stop and the indoor fan will run at preset speed.

2) Heating overload

a. If $T_{tube} \sim 126^{\circ}\text{F}$, the unit will return to its original operation state.

b. If $T_{tube} \geq 131^{\circ}\text{F}$, frequency rise is not allowed.

c. If $T_{tube} \geq 136^{\circ}\text{F}$, the compressor will run at reduced frequency.

d. If $T_{tube} \geq 144^{\circ}\text{F}$, the compressor will stop and the indoor fan will blow residue heat and then stop.

② Exhaust temperature protection of compressor

If exhaust temperature $\geq 208^{\circ}\text{F}$, frequency is not allowed to rise.

If exhaust temperature $\geq 217^{\circ}\text{F}$, the compressor will run at reduced frequency.

If exhaust temperature $\geq 230^{\circ}\text{F}$, the compressor will stop.

If exhaust temperature $\sim 194^{\circ}\text{F}$ and the compressor has stayed at stop for at least 3 minutes, the compressor will resume its operation.

③ Communication fault

If the unit fails to receive correct signals for durative 3 minutes, communication fault can be justified and the whole system will stop.

④ Module protection

Under module protection mode, the compressor will stop. When the compressor remains at stop for at least 3 minutes, the compressor will resume its operation. If module protection occurs six times in succession, the compressor will not be started again.

⑤ Overload protection

If temperature sensed by the overload sensor is over 239°F , the compressor will stop and the outdoor fan will stop with a time lag of 30 seconds. If temperature is below 203°F , the overload protection will be relieved.

If voltage on the DC bus is below 150V or over 420V, the compressor will stop and the outdoor fan will stop with a time lag of 30 seconds. When voltage on the DC bus returns to its normal value and the compressor has stayed at stop for at least 3 minutes, the compressor will resume its operation.

⑥ Faults of temperature sensors

Designation of sensors	Faults
Indoor ambient temperature	The sensor is detected to be open-circuited or short-circuited for successive 5 seconds
Indoor tube temperature	The sensor is detected to be open-circuited or short-circuited for successive 5 seconds
Outdoor ambient temperature	The sensor is detected to be open-circuited or short-circuited for successive 30 seconds
Outdoor tube temperature	The sensor is detected to be open-circuited or short-circuited for successive 30 seconds, and no detection is performed within 10 minutes after defrost begins.
Exhaust	After the compressor has operated for 3 minutes, the sensor is detected to be open-circuited or short-circuited for successive 30 seconds.
Overload	After the compressor has operated for 3 minutes, the sensor is detected to be open-circuited or short-circuited for successive 30 seconds.

Part II : Installation and Maintenance

7. Notes for Installation and Maintenance

Safety Precautions: Important!

Please read the safety precautions carefully before installation and maintenance.
The following contents are very important for installation and maintenance.

Please follow the instructions below.

- The installation or maintenance must accord with the instructions.
- Comply with all national electrical codes and local electrical codes.
- Pay attention to the warnings and cautions in this manual.
- All installation and maintenance shall be performed by distributor or qualified person.
- All electric work must be performed by a licensed technician according to local regulations and the instructions given in this manual.
- Be caution during installation and maintenance. Prohibit incorrect operation to prevent electric shock, casualty and other accidents.



Warnings

Electrical Safety Precautions:

1. Cut off the power supply of air conditioner before checking and maintenance.
2. The air condition must apply specialized circuit and prohibit share the same circuit with other appliances.
3. The air conditioner should be installed in suitable location and ensure the power plug is touchable.
4. Make sure each wiring terminal is connected firmly during installation and maintenance.
5. Have the unit adequately grounded. The grounding wire can't be used for other purposes.
6. Must apply protective accessories such as protective boards, cable-cross loop and wire clip.
7. The live wire, neutral wire and grounding wire of power supply must be corresponding to the live wire, neutral wire and grounding wire of the air conditioner.
8. The power cord and power connection wires can't be pressed by hard objects.
9. If power cord or connection wire is broken, it must be replaced by a qualified person.

10. If the power cord or connection wire is not long enough, please get the specialized power cord or connection wire from the manufacture or distributor. Prohibit prolong the wire by yourself.
11. For the air conditioner without plug, an air switch must be installed in the circuit. The air switch should be all-pole parting and the contact parting distance should be more than 1/8 inch.
12. Make sure all wires and pipes are connected properly and the valves are opened before energizing.
13. Check if there is electric leakage on the unit body. If yes, please eliminate the electric leakage.
14. Replace the fuse with a new one of the same specification if it is burnt down; don't replace it with a cooper wire or conducting wire.
15. If the unit is to be installed in a humid place, the circuit breaker must be installed.

Installation Safety Precautions:

1. Select the installation location according to the requirement of this manual.(See the requirements in installation part)
2. Handle unit transportation with care; the unit should not be carried by only one person if it is more than 44.09lb.
3. When installing the indoor unit and outdoor unit, a sufficient fixing bolt must be installed; make sure the installation support is firm.
4. Ware safety belt if the height of working is above acceptable standards.
5. Use equipped components or appointed components during installation.
6. Make sure no foreign objects are left in the unit after finishing installation.

Refrigerant Safety Precautions:

1. Avoid contact between refrigerant and fire as it generates poisonous gas; Prohibit prolong the connection pipe by welding.
2. Apply specified refrigerant only. Never have it mixed with any other refrigerant. Never have air remain in the refrigerant line as it may lead to rupture or other hazards.
3. Make sure no refrigerant gas is leaking out when installation is completed.
4. If there is refrigerant leakage, please take sufficient measure to minimize the density of refrigerant.
5. Never touch the refrigerant piping or compressor without wearing glove to avoid scald or frostbite.

Improper installation may lead to fire hazard, explosion, electric shock or injury.

Main Tools for Installation and Maintenance

<p>1. Level meter, measuring tape</p> 	<p>2. Screw driver</p> 	<p>3. Impact drill, drill head, electric drill</p> 
<p>4. Electroprobe</p> 	<p>5. Universal meter</p> 	<p>6. Torque wrench, open-end wrench, inner hexagon spanner</p> 
<p>7. Electronic leakage detector</p> 	<p>8. Vacuum pump</p> 	<p>9. Pressure meter</p> 
<p>10. Pipe pliers, pipe cutter</p> 	<p>11. Pipe expander, pipe bender</p> 	<p>12. Soldering appliance, refrigerant container</p> 

8. Installation

8.1 Installation Dimension Diagram

STOP

This product is precharged with refrigerant for a **25 feet** of line set.

If **MORE** than 25 feet of line set is required, refer to your Ideal-Air Service Manual for refrigerant charging chart.

For line sets between 25' & 10' in length, **REMOVE .65 oz** of R410A refrigerant per line feed.

According to manufacturer's specifications, under no circumstances should the line set be shorter than 10' in length.

If you need further assistance, please contact:
Ideal-Air Tech Support
 877-943-3251
support@ideal-air.com

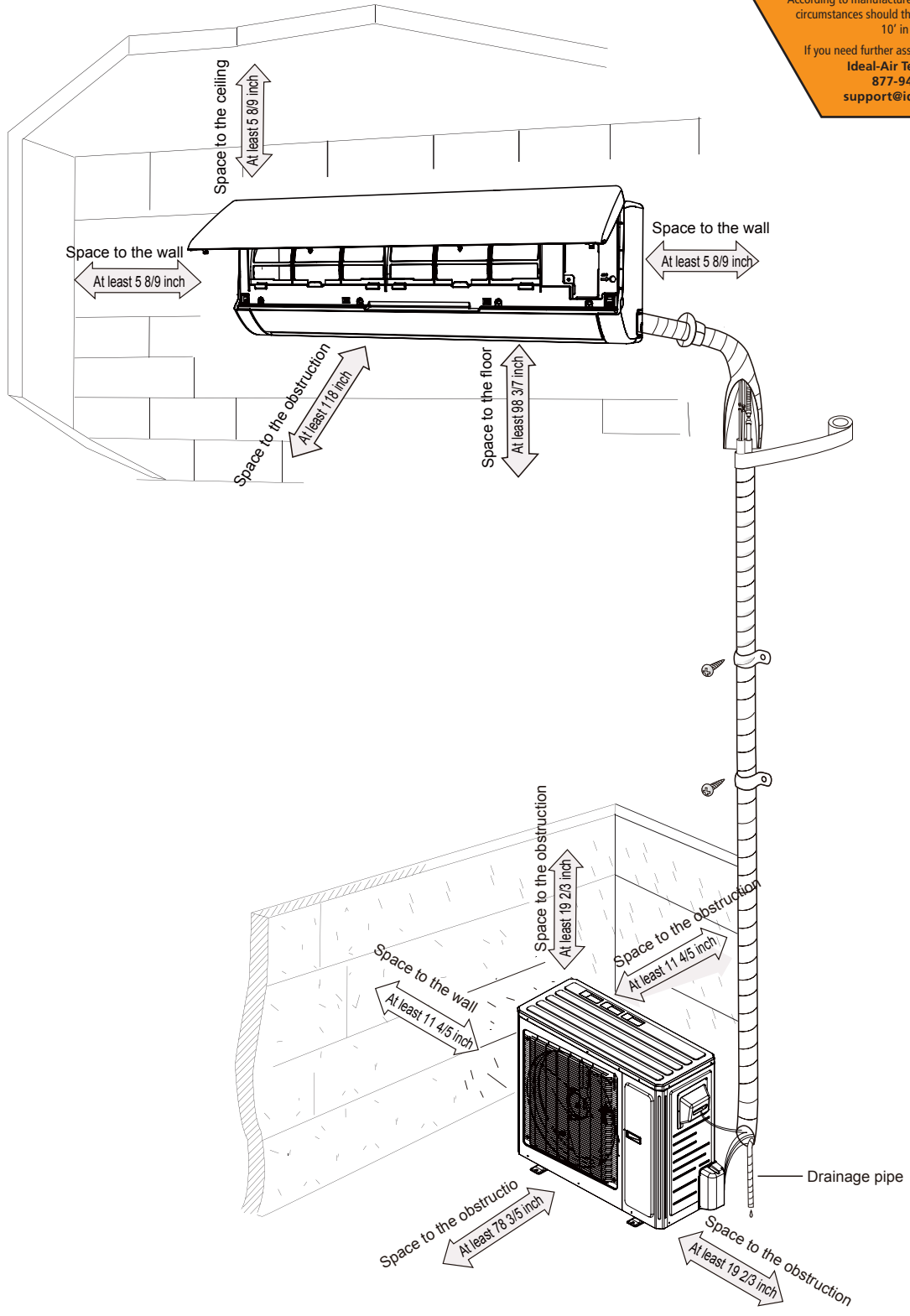

Installation procedures

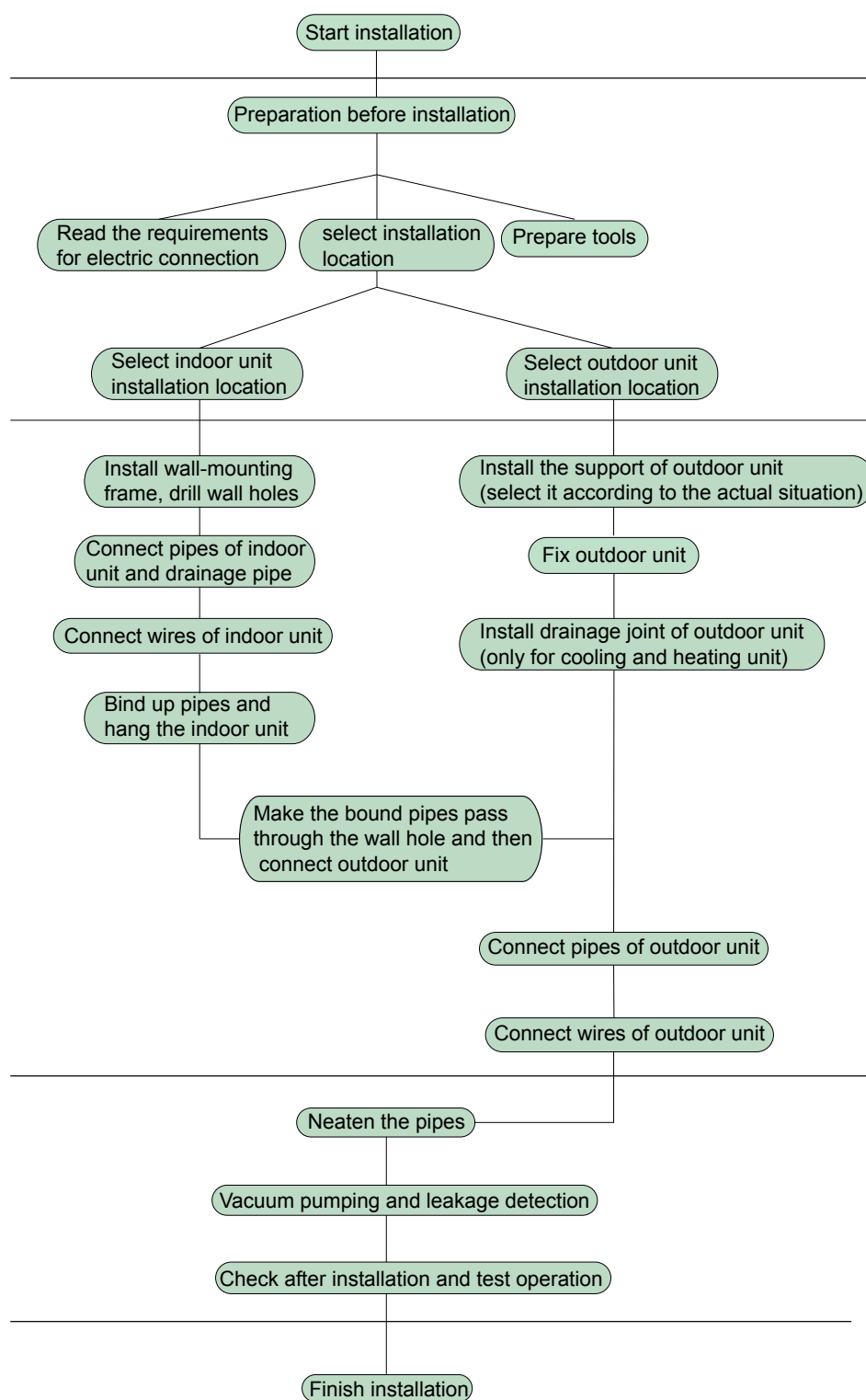

Note: this flow is only for reference; please find the more detailed installation steps in this section.

8.2 Installation Parts-checking

No.	Name	No.	Name
1	Indoor unit	8	Sealing gum
2	Outdoor unit	9	Wrapping tape
3	Connection pipe	10	Support of outdoor unit
4	Drainage pipe	11	Fixing screw
5	Wall-mounting frame	12	Drainage plug(cooling and heating unit)
6	Connecting cable(power cord)	13	Owner's manual, remote controller
7	Wall pipe		

⚠ Note:

- 1.Please contact the local agent for installation.
- 2.Don't use unqualified power cord

8.3 Selection of Installation Location

1. Basic Requirement:

Installing the unit in the following places may cause malfunction. If it is unavoidable, please consult the local dealer:

- (1) The place with strong heat sources, vapors, flammable or explosive gas, or volatile objects spread in the air.
- (2) The place with high-frequency devices (such as welding machine, medical equipment).
- (3) The place near coast area.
- (4) The place with oil or fumes in the air.
- (5) The place with sulfured gas.
- (6) Other places with special circumstances.

2. Indoor Unit:

- (1) There should be no obstruction near air inlet and air outlet.
- (2) Select a location where the condensation water can be dispersed easily and won't affect other people.
- (3) Select a location which is convenient to connect the outdoor unit and near the power socket.
- (4) Select a location which is out of reach for children.
- (5) The location should be able to withstand the weight of indoor unit and won't increase noise and vibration.
- (6) The appliance must be installed 98 3/7 inch above floor .
- (7) Don't install the indoor unit right above the electric appliance.
- (8) The appliance shall not be installed in the laundry.

3. Outdoor Unit:

- (1) Select a location where the noise and outflow air emitted by the outdoor unit will not affect neighborhood.
- (2) The location should be well ventilated and dry, in which the outdoor unit won't be exposed directly to sunlight or strong wind.
- (3) The location should be able to withstand the weight of outdoor unit.
- (4) Make sure that the installation follows the requirement of installation dimension diagram.
- (5)Select a location which is out of reach for children and far away from animals or plants.If it is unavoidable, please add fence for safety purpose.

8.4 Electric Connection Requirement

1. Safety Precaution

- (1) Must follow the electric safety regulations when installing the unit.
- (2) According to the local safety regulations, use qualified power supply circuit and air switch.
- (3) Make sure the power supply matches with the requirement of air conditioner. Unstable power supply or incorrect wiring may result in electric shock,fire hazard or malfunction. Please install proper power supply cables before using the air conditioner.

Air-conditioner	Air switch capacity
30K	30A
36K	40A

- (4) Properly connect the live wire, neutral wire and grounding wire of power socket.
- (5) Be sure to cut off the power supply before proceeding any work related to electricity and safety.
- (6) Do not put through the power before finishing installation
- (7) For appliances with type Y attachment,the instructions shall contain the substance of thefollowing.If the supply cord is damaged,it must be replaced by the manufacturer,its service agent or similarly qualified persons in order to avoid a hazard
- (8) The temperature of refrigerant circuit will be high, please keep the interconnection cable away from the copper tube.

2. Grounding Requirement:

- (1) The air conditioner is first class electric appliance. It must be properly grounding with specialized grounding device by a professional. Please make sure it is always grounded effectively, otherwise it may cause electric shock.
- (2) The yellow-green wire in air conditioner is grounding wire, which can't be used for other purposes.
- (3) The grounding resistance should comply with national electric safety regulations.
- (4) The appliance must be positioned so that the plug is accessible.
- (5) An all-pole disconnection switch having a contact separation of at least 1/8 inch in all poles should be connected in fixed wiring.
- (6) Including an air switch with suitable capacity, please note the following table. Air switch should be included magnet buckle and heating buckle function, it can protect the circuit-short and overload. (Caution: please do not use the fuse only for protect the circuit)

8.5 Installation of Indoor Unit

1. Choosing Installation location

Recommend the installation location to the client and then confirm it with the client

2. Install Wall-mounting Frame

- (1) Hang the wall-mounting frame on the wall; adjust it in horizontal position with the level meter and then point out the screw fixing holes on the wall
- (2) Drill the screw fixing holes on the wall with impact drill (the specification of drill head should be the same as the plastic expansion particle) and then fill the plastic expansion particles

in the holes.

(3) Fix the wall-mounting frame on the wall with tapping screws (ST4.2X25TA) and then check if the frame is firmly installed by pulling the frame. If the plastic expansion particle is loose, please drill another fixing hole nearby.

3. Install Wall-mounting Frame

(1) Choose the position of piping hole according to the direction of outlet pipe. The position of piping hole should be a little lower than the wall-mounted frame. (As show in Fig.1)

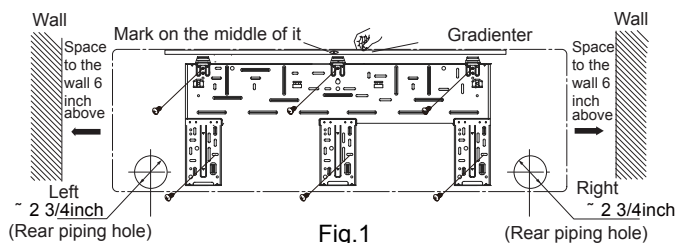

Fig. 1

(2) Open a piping hole with the diameter of 2 3/4inch on the selected outlet pipe position. In order to drain smoothly, slant the piping hole on the wall slightly downward to the outdoor side with the gradient of 5-10°. (As show in Fig.2)

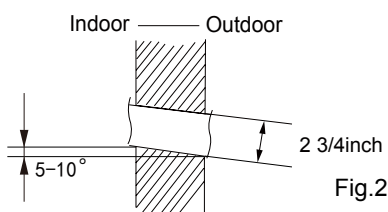

Fig. 2

⚠ Note:

- (1) Pay attention to dust prevention and take relevant safety measures when opening the hole.
- (2) The plastic expansion particles are not provided and should be bought locally.

4. Outlet Pipe

(1) The pipe can be led out in the direction of right, rear right, left or rear left. (As show in Fig.3)

(2) When selecting leading out the pipe from left or right, please cut off the corresponding hole on the bottom case. (As show in Fig.4)

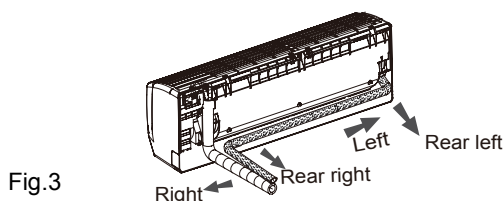

Fig. 3

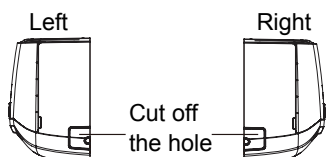

Fig. 4

STOP

This product is precharged with refrigerant for a 25 feet of line set.

If MORE than 25 feet of line set is required, refer to your Ideal-Air Service Manual for refrigerant charging chart.

For line sets between 25' & 10' in length, REMOVE .65 oz of R410A refrigerant per line feed.

According to manufacturer's specifications, under no circumstances should the line set be shorter than 10' in length.

If you need further assistance, please contact:
Ideal-Air Tech Support
877-943-3251
support@ideal-air.com

5. Connect the Pipe of Indoor Unit

(1) Aim the pipe joint at the corresponding bellmouth. (As show in Fig.5)

(2) Pretightening the union nut with hand.

(3) Adjust the torque force by referring to the following sheet. Place the open-end wrench on the pipe joint and place the torque wrench on the union nut. Tighten the union nut with torque wrench. (As show in Fig.6)

(4) Wrap the indoor pipe and joint of connection pipe with insulating pipe, and then wrap it with tape. (As show in Fig.7)

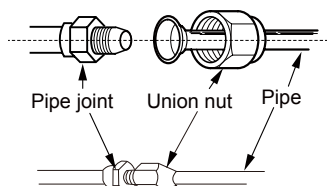

Fig. 5

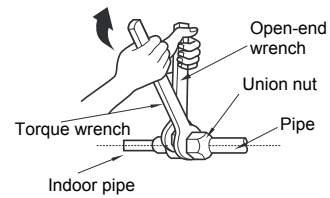

Fig. 6

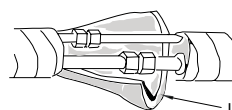

Fig. 7

Refer to the following table for wrench moment of force:

Hex nut diameter(inch)	Tightening torque(ft-lbf)
Φ1/4	11.10~14.75
Φ3/8	20.12~29.50
Φ1/2	33.19~40.56
Φ5/8	44.24~47.94
Φ3/4	51.32~55.31

6. Install Drain Hose

(1) Connect the drain hose to the outlet pipe of indoor unit. (As show in Fig.8)

(2) Bind the joint with tape. (As show in Fig.9)

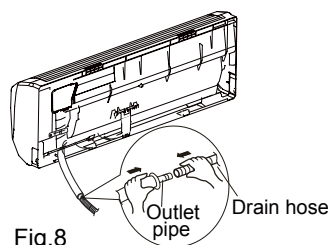

Fig. 8

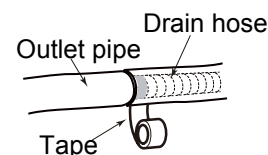

Fig. 9

⚠ Note:

- (1) Add insulating pipe in the indoor drain hose in order to prevent condensation.
- (2) The plastic expansion particles are not provided. (As show in Fig.10)

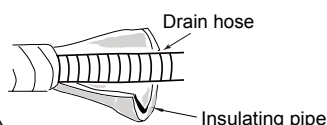

Fig. 10

7. Connect Wire of Indoor Unit

(1) Open the panel, remove the screw on the wiring cover and then take down the cover.(As show in Fig.11)

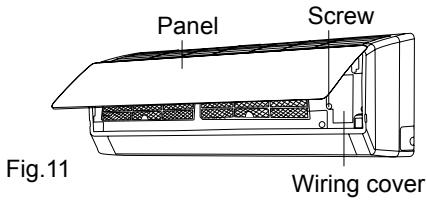
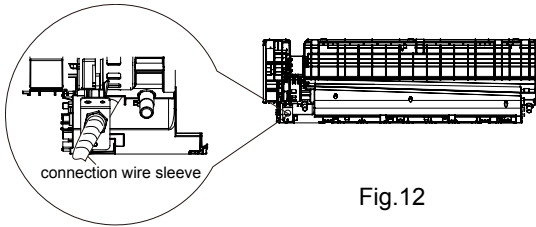
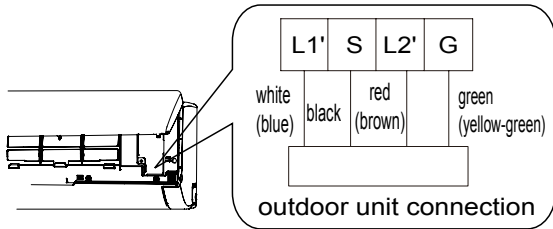

Fig.11

(2) Fix the wire crossing board on connection wire sleeve at the bottom case; let the connection wire sleeve go through the wire crossing hole at the back of indoor unit, and then pull it out from the front.(As show in Fig.12)



(3) Remove the wire clip; connect the power connection wire to the wiring terminal according to the color; tighten the screw and then fix the power connection wire with wire clip.(As show in Fig.13)



Note: The wiring connect is for reference only, please refer to the actual one.

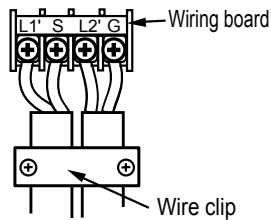

Fig.13

(4) Put wiring cover back and then tighten the screw.
 (5) Close the panel.

⚠ Note:

- (1) All wires of indoor unit and outdoor unit should be connected by a professional.
- (2) If the length of power connection wire is insufficient, please contact the supplier for a new one. Avoid extending the wire by yourself.
- (3) For the air conditioner with plug, the plug should be reachable after finishing installation
- (4) For the air conditioner without plug, an air switch must be installed in the line. The air switch should be all-pole parting and the contact parting distance should be more than 1/8inch.

8. Bind up Pipe

- (1) Bind up the connection pipe, power cord and drain hose with the band.(As show in Fig.14)
- (2) Reserve a certain length of drain hose and power cord for installation when binding to a certain degree, separate the indoor power and then separate the drain hose.(As show in Fig.15)
- (3) Bind them evenly.
- (4) The liquid pipe and gas pipe should be bound separately at the end.

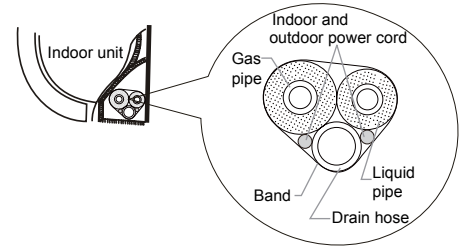

Fig.14

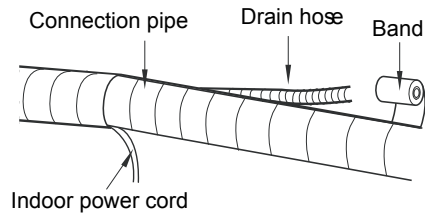

Fig.15

⚠ Note:

- (1) The power cord and control wire can't be crossed or winding.
- (2) The drain hose should be bound at the bottom.

9. Hang the Indoor Unit

- (1) Put the bound pipes in the wall pipe and then make them pass through the wall hole.
- (2) Hang the indoor unit on the wall-mounting frame.
- (3) Stuff the gap between pipes and wall hole with sealing gum.
- (4) Fix the wall pipe.(As show in Fig.16)
- (5) Check if the indoor unit is installed firmly and closed to the wall.(As show in Fig.17)

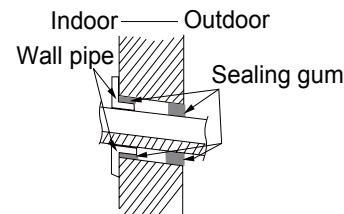

Fig.16

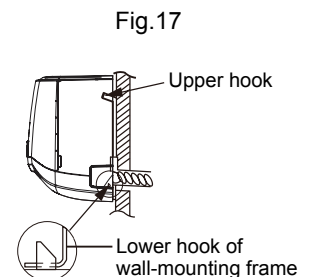

Fig.17

⚠ Note:

Do not bend the drain hose too excessively in order to prevent blocking.

8.6 Installation of Outdoor Unit

1. Fix the Support of Outdoor Unit(Select it according to the actual installation situation)

- (1) Select installation location according to the house structure.
- (2) Fix the support of outdoor unit on the selected location with expansion screws.

⚠ Note:

- (1) Take sufficient protective measures when installing the outdoor unit.
- (2) Make sure the support can withstand at least four times the unit weight.
- (3) The outdoor unit should be installed at least 1 1/6 inch above the floor in order to install drain joint.(As show in Fig.18)
- (4) For the unit with cooling capacity of 2300W~5000W, 6 expansion screws are needed; for the unit with cooling capacity of 6000W~8000W, 8 expansion screws are needed; for the unit with cooling capacity of 10000W~16000W, 10 expansion screws are needed.

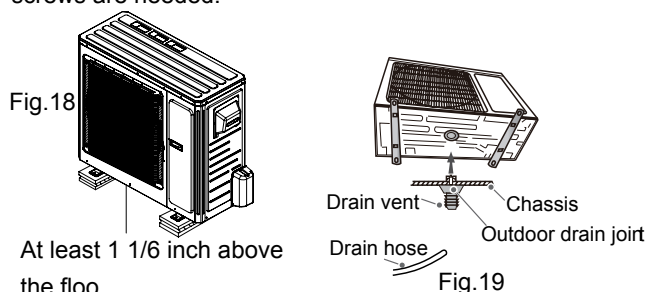

2. Install Drain Joint(Only for cooling and heating unit)

- (1) Connect the outdoor drain joint into the hole on the chassis.
 - (2) Connect the drain hose into the drain vent.
- (As show in Fig.19)

3. Fix Outdoor Unit

- (1) Place the outdoor unit on the support.
 - (2) Fix the foot holes of outdoor unit with bolts.
- (As show in Fig.20)

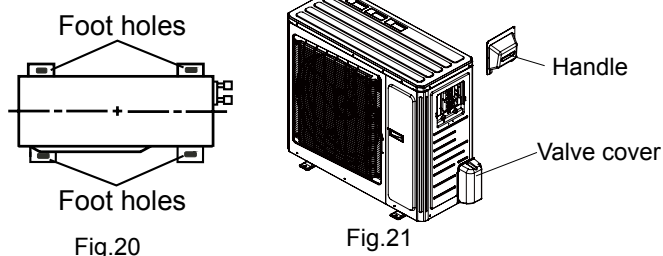

4. Connect Indoor and Outdoor Pipes

- (1) Remove the screw on the right handle and valve cover of outdoor unit and then remove the handle and valve cover.(As show in Fig.21)
- (2) Remove the screw cap of valve and aim the pipe joint at the bellmouth of pipe.(As show in Fig.22)

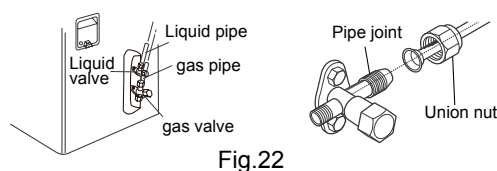

- (3) Pretightening the union nut with hand.
- (4) Tighten the union nut with torque wrench .

Refer to the following table for wrench moment of force:

Hex nut diameter(inch)	Tightening torque(ft·lbf)
Φ1/4	11.10~14.75
Φ3/8	20.12~29.50
Φ1/2	33.19~40.56
Φ5/8	44.24~47.94
Φ3/4	51.32~55.31

5. Connect Outdoor Electric Wire

- (1) Let the connection wire sleeve go through the two holes of retaining plate; tighten the connection joint of sleeve and retaining plate; remove the wire clip; connect the power connection wire and power cord to the wiring terminal according to the color; fix them with screws
- (2) Fix the power connection wire and power cord with wire clip.
- (3) Fix the stopper on handle with screw.(As show in Fig.23)

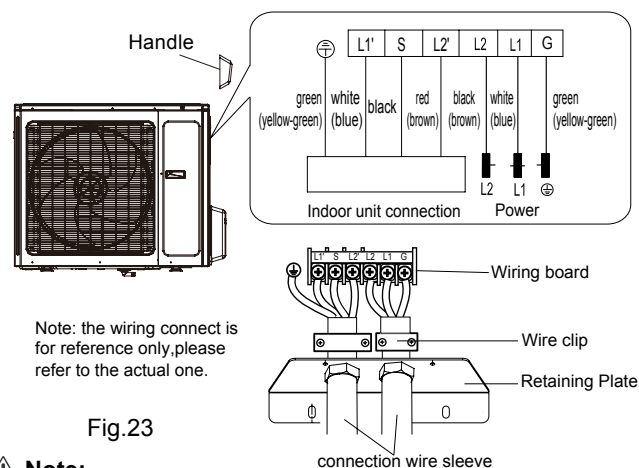

⚠ Note:

- (1) After tightening the screw, pull the power cord slightly to check if it is firm
- (2) Never cut the power connection wire to prolong or shorten the distance.

6. Neaten the Pipes

- (1) The pipes should be placed along the wall, bent reasonably and hidden possibly. Min. semidiameter of bending the pipe is 4 inch.
- (2) If the outdoor unit is higher than the wall hole, you must set a U-shaped curve in the pipe before pipe goes into the room, in order to prevent rain from getting into the room.(As show in Fig.24)

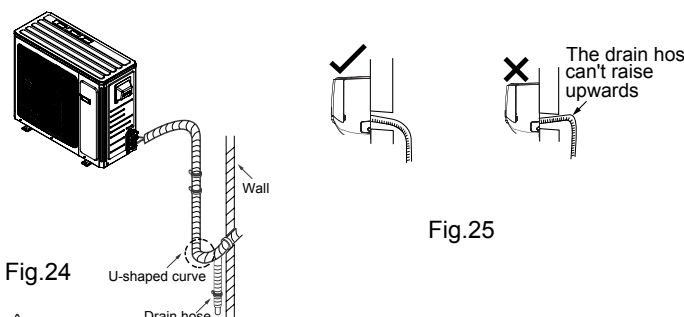

Fig.24

Fig.25

⚠ Note:

- (1) The through-wall height of drain hose shouldn't be higher than the outlet pipe hole of indoor unit.(As show in Fig.25)
- (2) Slant the drain hose slightly downwards. The drain hose can't be curved, raised and fluctuant, etc.(As show in Fig.26)

(3) The water outlet can't be placed in water in order to drain smoothly.(As show in Fig.27)

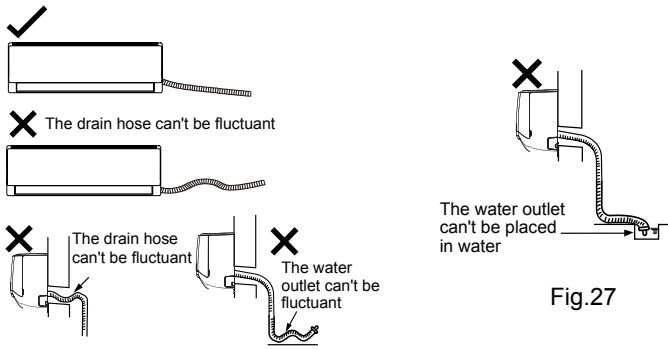

Fig.26

Fig.27

8.7 Vacuum Pumping and Leak Detection

1. Use Vacuum Pump

- (1) Remove the valve caps on the liquid valve and gas valve and the nut of refrigerant charging vent.
- (2) Connect the charging hose of piezometer to the refrigerant charging vent of gas valve and then connect the other charging hose to the vacuum pump.
- (3) Open the piezometer completely and operate for 10-15min to check if the pressure of piezometer remains in -0.1MPa.
- (4) Close the vacuum pump and maintain this status for 1-2min to check if the pressure of piezometer remains in -0.1MPa. If the pressure decreases, there may be leakage.
- (5) Remove the piezometer, open the valve core of liquid valve and gas valve completely with inner hexagon spanner.
- (6) Tighten the screw caps of valves and refrigerant charging vent.(As show in Fig.28)

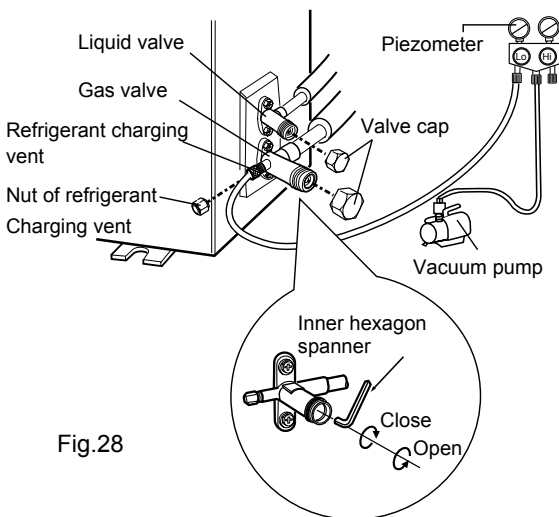

Fig.28

2. Leakage Detection

- (1) With leakage detector:
Check if there is leakage with leakage detector.
- (2) With soap water:
If leakage detector is not available, please use soap water for leakage detection. Apply soap water at the suspected position and keep the soap water for more than 3min. If there are air bubbles coming out of this position, there's a leakage.

8.8 Check after Installation and Test Operation

1. Check after Installation

Check according to the following requirement after finishing installation.

NO.	Items to be checked	Possible malfunction
1	Has the unit been installed firmly	The unit may drop, shake or emit noise.
2	Have you done the refrigerant leakage test?	It may cause insufficient cooling (heating) capacity.
3	Is heat insulation of pipeline sufficient	It may cause condensation and water dripping.
4	Is water drained well?	It may cause condensation and water dripping.
5	Is the voltage of power supply according to the voltage marked on the nameplate?	It may cause malfunction or damage the parts.
6	Is electric wiring and pipeline installed correctly?	It may cause malfunction or damage the parts.
7	Is the unit grounded securely?	It may cause electric leakage.
8	Does the power cord follow the specification	It may cause malfunction or damage the parts.
9	Is there any obstruction in air inlet and air outlet?	It may cause insufficient cooling (heating).
10	The dust and sundries caused during installation are removed?	It may cause malfunction or damaging the parts.
11	The gas valve and liquid valve of connection pipe are open completely?	It may cause insufficient cooling (heating) capacity.

2. Test Operation

- (1) Preparation of test operation
 - The client approves the air conditioner installation.
 - Specify the important notes for air conditioner to the client.
- (2) Method of test operation
 - Put through the power, press ON/OFF button on the remote controller to start operation.
 - Press MODE button to select AUTO, COOL, DRY, FAN and HEAT to check whether the operation is normal or not.
 - If the ambient temperature is lower than 16°C(61°F), the air conditioner can't start cooling.

9. Troubleshooting

9.1 Flashing LED of Indoor/Outdoor Unit and Primary Judgement

NO.	Malfunction Name	Display Method of Indoor Unit			Display Method of Outdoor Unit			A/C status	Possible Causes	
		Dual-8 Code Display	Indicator Display (during blinking, ON 0.5s and OFF 0.5s)	Operation Indicator	Cool Indicator	Heating Indicator	Yellow Indicator			Red Indicator
1	High pressure protection of system	E1	OFF 3s and blink once						During cooling and drying operation, except indoor fan operates, all loads stop operation. During heating operation, the complete unit stops.	Possible reasons: 1. Refrigerant was superabundant; 2. Poor heat exchange (including filth blockage of heat exchanger and bad radiating environment); Ambient temperature is too high.
2	Antifreezing protection	E2	OFF 3S and blink twice				OFF 1S and blink 3 times		During cooling and drying operation, compressor and outdoor fan stop while indoor fan operates.	1. Poor air-return in indoor unit; 2. Fan speed is abnormal; 3. Evaporator is dirty.
3	In defect of refrigerant	F0					OFF 1S and blink 9 times		The Dual-8 Code Display will show F0 and the complete unit stops.	1.In defect of refrigerant; 2.Indoor evaporator temperature sensor works abnormally; 3.The unit has been plugged up somewhere.
4	High discharge temperature protection of compressor	E4	OFF 3S and blink 4 times				OFF 1S and blink 7 times		During cooling and drying operation, compressor and outdoor fan stop while indoor fan operates. During heating operation, all loads stop.	Please refer to the malfunction analysis (discharge protection, overload).
5	Overcurrent protection	E5	OFF 3S and blink 5 times				OFF 1S and blink 5 times		During cooling and drying operation, compressor and outdoor fan stop while indoor fan operates. During heating operation, all loads stop.	1. Supply voltage is unstable; 2. Supply voltage is too low and load is too high; 3. Evaporator is dirty.
6	Communication Malfunction	E6	OFF 3S and blink 6 times				Always ON		During cooling operation, compressor stops while indoor fan motor operates. During heating operation, the complete unit stops.	Refer to the corresponding malfunction analysis.
7	High temperature resistant protection	E8	OFF 3S and blink 8 times				OFF 1S and blink 6 times		During cooling operation: compressor will stop while indoor fan will operate. During heating operation, the complete unit stops.	Refer to the malfunction analysis (overload, high temperature resistant).
8	EEPROM malfunction	EE			OFF 3S and blink 15 times		OFF 1S and blink 11 times		During cooling and drying operation, compressor will stop while indoor fan will operate; During heating operation, the complete unit will stop	Replace outdoor control panel AP1
9	Limit/decrease frequency due to high temperature of module	EU		OFF 3S and blink 6 times	OFF 3S and blink 6 times				All loads operate normally, while operation frequency for compressor is decreased	Discharging after the complete unit is de-energized for 20mins, check whether the thermal grease on IPM Module of outdoor control panel AP1 is sufficient and whether the radiator is inserted tightly. If its no use, please replace control panel AP1.
10	Malfunction protection of jumper cap	C5	OFF 3S and blink 15 times						Wireless remote receiver and button are effective, but can not dispose the related command	1. No jumper cap insert on mainboard. 2. Incorrect insert of jumper cap. 3. Jumper cap damaged. 4. Abnormal detecting circuit of mainboard.

NO.	Malfunction Name	Display Method of Indoor Unit			Display Method of Outdoor Unit			A/C status	Possible Causes	
		Dual-8 Code Display	Indicator Display (during blinking, ON 0.5s and OFF 0.5s)			Indicator has 3 kinds of display status and during blinking, ON 0.5s and OFF 0.5s				
			Operation Indicator	Cool Indicator	Heating Indicator	Yellow Indicator	Red Indicator			Green Indicator
11	Gathering refrigerant	Fo	OFF 3S and blink 1 times	OFF 3S and blink 1 times		OFF 1S and blink 17 times			When the outdoor unit receive signal of Gathering refrigerant ,the system will be forced to run under cooling mode for gathering refrigerant	Nominal cooling mode
12	Indoor ambient temperature sensor is open/short circuited	F1		OFF 3S and blink once					During cooling and drying operation, indoor unit operates while other loads will stop; during heating operation, the complete unit will stop operation.	<ol style="list-style-type: none"> 1. Loosening or bad contact of indoor ambient temp. sensor and mainboard terminal. 2. Components in mainboard fell down leads short circuit. 3. Indoor ambient temp. sensor damaged.(check with sensor resistance value chart) 4. Mainboard damaged.
13	Indoor evaporator temperature sensor is open/short circuited	F2		OFF 3S and blink twice					AC stops operation once reaches the setting temperature. Cooling, drying: internal fan motor stops operation while other loads stop operation; heating: AC stop operation	<ol style="list-style-type: none"> 1. Loosening or bad contact of Indoor evaporator temp. sensor and mainboard terminal. 2. Components on the mainboard fall down leads short circuit. 3. Indoor evaporator temp. sensor damaged.(check temp. sensor value chart for testing) 4. Mainboard damaged.
14	Outdoor ambient temperature sensor is open/short circuited	F3		OFF 3S and blink 3 times			OFF 1S and blink 6 times		During cooling and drying operating, compressor stops while indoor fan operates; During heating operation, the complete unit will stop operation	Outdoor temperature sensor hasnt been connected well or is damaged. Please check it by referring to the resistance table for temperature sensor)
15	Outdoor condenser temperature sensor is open/short circuited	F4		OFF 3S and blink 4 times			OFF 1S and blink 5 times		During cooling and drying operation, compressor stops while indoor fan will operate; During heating operation, the complete unit will stop operation.	Outdoor temperature sensor hasnt been connected well or is damaged. Please check it by referring to the resistance table for temperature sensor)
16	Outdoor discharge temperature sensor is open/short circuited	F5		OFF 3S and blink 5 times			OFF 1S and blink 7 times		During cooling and drying operation, compressor will sop after operating for about 3 mins, while indoor fan will operate; During heating operation, the complete unit will stop after operating for about 3 mins.	<ol style="list-style-type: none"> 1.Outdoor temperature sensor hasnt been connected well or is damaged. Please check it by referring to the resistance table for temperature sensor) 2.The head of temperature sensor hasnt been inserted into the copper tube
17	Limit/ decrease frequency due to overload	F6		OFF 3S and blink for 6 times			OFF 1S and blink 3 times		All loads operate normally, while operation frequency for compressor is decreased	Refer to the malfunction analysis (overload, high temperature resistant)
18	Decrease frequency due to overcurrent	F8		OFF 3S and blink 8 times			OFF 1S and blink once		All loads operate normally, while operation frequency for compressor is decreased	The input supply voltage is too low; System pressure is too high and overload

NO.	Malfunction Name	Display Method of Indoor Unit			Display Method of Outdoor Unit			A/C status	Possible Causes	
		Dual-8 Code Display	Indicator Display (during blinking, ON 0.5s and OFF 0.5s)			Indicator has 3 kinds of display status and during blinking, ON 0.5s and OFF 0.5s				
			Operation Indicator	Cool Indicator	Heating Indicator	Yellow Indicator	Red Indicator			Green Indicator
19	Decrease frequency due to high air discharge	F9		OFF 3S and blink 9 times				OFF 1S and blink twice	All loads operate normally, while operation frequency for compressor is decreased	Overload or temperature is too high; Refrigerant is insufficient; Malfunction of electric expansion valve (EKV)
20	Limit/ decrease frequency due to antifreezing	FH		OFF 3S and blink 2 times	OFF 3S and blink 2 times			OFF 1S and blink 4 times	All loads operate normally, while operation frequency for compressor is decreased	Poor air-return in indoor unit or fan speed is too low
21	Voltage for DC bus-bar is too high	PH		OFF 3S and blink 11 times				OFF 1S and blink 13 times	During cooling and drying operation, compressor will stop while indoor fan will operate; During heating operation, the complete unit will stop operation.	1. Measure the voltage of position L and N on wiring board (XT), if the voltage is higher than 265VAC, turn on the unit after the supply voltage is increased to the normal range. 2.If the AC input is normal, measure the voltage of electrolytic capacitor C on control panel (AP1), if its normal, theres malfunction for the circuit, please replace the control panel (AP1)
22	Voltage of DC bus-bar is too low	PL			OFF 3S and blink 21 times			OFF 1S and blink 12 times	During cooling and drying operation, compressor will stop while indoor fan will operate; During heating operation, the complete unit will stop	1. Measure the voltage of position L and N on wiring board (XT), if the voltage is higher than 150VAC, turn on the unit after the supply voltage is increased to the normal range. 2.If the AC input is normal, measure the voltage of electrolytic capacitor C on control panel (AP1), if its normal, theres malfunction for the circuit, please replace the control panel (AP1)
23	Compressor Min frequency in test state	P0		(during blinking, ON 0.25s and OFF 0.25s)	(during blinking, ON 0.25s and OFF 0.25s)					Showing during min. cooling or min. heating test
24	Compressor rated frequency in test state	P1		(during blinking, ON 0.25s and OFF 0.25s)	(during blinking, ON 0.25s and OFF 0.25s)					Showing during nominal cooling or nominal heating test
25	Compressor maximum frequency in test state	P2		(during blinking, ON 0.25s and OFF 0.25s)	(during blinking, ON 0.25s and OFF 0.25s)					Showing during max. cooling or max. heating test

NO.	Malfunction Name	Display Method of Indoor Unit			Display Method of Outdoor Unit			A/C status	Possible Causes
		Dual-8 Code Display	Indicator Display (during blinking, ON 0.5s and OFF 0.5s)		Indicator has 3 kinds of display status and during blinking, ON 0.5s and OFF 0.5s				
			Operation Indicator	Cool Indicator	Heating Indicator	Yellow Indicator	Red Indicator		
26	Compressor intermediate frequency in test state	P3		(during blinking, ON 0.25s and OFF 0.25s)	(during blinking, ON 0.25s and OFF 0.25s)				Showing during middle cooling or middle heating test
27	Overcurrent protection of phase current for compressor	P5		OFF 3S and blink 15 times				During cooling and drying operation, compressor will stop while indoor fan will operate; During heating operation, the complete unit will stop operation.	Refer to the malfunction analysis (IPM protection, loss of synchronism protection and overcurrent protection of phase current for compressor).
28	Charging malfunction of capacitor	PU			OFF 3S and blink 17 times			During cooling and drying operation, compressor will stop while indoor fan will operate; During heating operation, the complete unit will stop	Refer to the part three—charging malfunction analysis of capacitor
29	Malfunction of module temperature sensor circuit	P7			OFF 3S and blink 18 times			During cooling and drying operation, compressor will stop while indoor fan will operate; During heating operation, the complete unit will stop	Replace outdoor control panel AP1
30	Module high temperature protection	P8			OFF 3S and blink 19 times			During cooling operation, compressor will stop while indoor fan will operate; During heating operation, the complete unit will stop	After the complete unit is de-energized for 20mins, check whether the thermal grease on IPM Module of outdoor control panel AP1 is sufficient and whether the radiator is inserted tightly. If its no use, please replace control panel AP1.
31	Decrease frequency due to high temperature resistant during heating operation	H0			OFF 3S and blink 10 times			All loads operate normally, while operation frequency for compressor is decreased	Refer to the malfunction analysis (overload, high temperature resistant)
32	Static dedusting protection	H2			OFF 3S and blink twice				
33	Overload protection for compressor	H3			OFF 3S and blink 3 times	OFF 1S and blink 8 times		During cooling and drying operation, compressor will stop while indoor fan will operate; During heating operation, the complete unit will stop operation.	1. Wiring terminal OVC-COMP is loosened. In normal state, the resistance for this terminal should be less than 1ohm. 2. Refer to the malfunction analysis (discharge protection, overload)

NO.	Malfunction Name	Display Method of Indoor Unit			Display Method of Outdoor Unit			A/C status	Possible Causes	
		Dual-8 Code Display	Indicator Display (during blinking, ON 0.5s and OFF 0.5s)			Indicator has 3 kinds of display status and during blinking, ON 0.5s and OFF 0.5s				
			Operation Indicator	Cool Indicator	Heating Indicator	Yellow Indicator	Red Indicator			Green Indicator
34	System is abnormal	H4			OFF 3S and blink 4 times	OFF 1S and blink 6 times			During cooling and drying operation, compressor will stop while indoor fan will operate; During heating operation, the complete unit will stop operation.	Refer to the malfunction analysis (overload, high temperature resistant)
35	IPM protection	H5			OFF 3S and blink 5 times	OFF 1S and blink 4 times			During cooling and drying operation, compressor will stop while indoor fan will operate; During heating operation, the complete unit will stop operation.	Refer to the malfunction analysis (IPM protection, loss of synchronism protection and overcurrent protection of phase current for compressor.
36	Module temperature is too high	H5			OFF 3S and blink 5 times	OFF 1S and blink 10 times				
37	Internal motor (fan motor) do not operate	H6	OFF 3S and blink 11 times						Internal fan motor, external fan motor, compressor and electric heater stop operation,guide louver stops at present location.	1. Bad contact of DC motor feedback terminal. 2. Bad contact of DC motor control end. 3. Fan motor is stalling. 4. Motor malfunction. 5. Malfunction of mainboard rev detecting circuit.
38	Desynchronizing of compressor	H7			OFF 3S and blink 7 times				During cooling and drying operation, compressor will stop while indoor fan will operate; During heating operation, the complete unit will stop operation.	Refer to the malfunction analysis (IPM protection, loss of synchronism protection and overcurrent protection of phase current for compressor.
39	PFC protection	HC			OFF 3S and blink 6 times	OFF 1S and blink 14 times			During cooling and drying operation, compressor will stop while indoor fan will operate; During heating operation, the complete unit will stop operation.	Refer to the malfunction analysis
40	Outdoor DC fan motor malfunction	L3	OFF 3S and blink 23 times				OFF 1S and blink 14 times		Outdoor DC fan motor malfunction lead to compressor stop operation,	DC fan motor malfunction or system blocked or the connector loosed
41	power protection	L9	OFF 3S and blink 20 times				OFF 1S and blink 9 times		compressor stop operation and Outdoor fan motor will stop 30s latter , 3 minutes latter fan motor and compressor will restart	To protect the electrical components when detect high power
42	Indoor unit and outdoor unit doesn't match	LP	OFF 3S and blink 19 times				OFF 1S and blink 16 times		compressor and Outdoor fan motor can't work	Indoor unit and outdoor unit doesn't match
43	Failure start-up	LC			OFF 3S and blink 11 times				During cooling and drying operation, compressor will stop while indoor fan will operate; During heating operation, the complete unit will stop operation.	Refer to the malfunction analysis

NO.	Malfunction Name	Display Method of Indoor Unit			Display Method of Outdoor Unit			A/C status	Possible Causes	
		Dual-8 Code Display	Indicator Display (during blinking, ON 0.5s and OFF 0.5s)			Indicator has 3 kinds of display status and during blinking, ON 0.5s and OFF 0.5s				
			Operation Indicator	Cool Indicator	Heating Indicator	Yellow Indicator	Red Indicator			Green Indicator
44	Malfunction of phase current detection circuit for compressor	U1			OFF 3S and blink 13 times				During cooling and drying operation, compressor will stop while indoor fan will operate; During heating operation, the complete unit will stop	Replace outdoor control panel AP1
45	Malfunction of voltage dropping for DC bus-bar	U3			OFF 3S and blink 20 times				During cooling and drying operation, compressor will stop while indoor fan will operate; During heating operation, the complete unit will stop	Supply voltage is unstable
46	Malfunction of complete units current detection	U5			OFF 3S and blink 13 times				During cooling and drying operation, the compressor will stop while indoor fan will operate; During heating operating, the complete unit will stop operation.	Theres circuit malfunction on outdoor units control panel AP1, please replace the outdoor units control panel AP1.
47	The four-way valve is abnormal	U7			OFF 3S and blink 20 times				If this malfunction occurs during heating operation, the complete unit will stop operation.	1.Supply voltage is lower than AC175V; 2.Wiring terminal 4V is loosened or broken; 3.4V is damaged, please replace 4V.
48	Zero-crossing malfunction of outdoor unit	U9	OFF 3S and blink 18 times						During cooling operation, compressor will stop while indoor fan will operate; during heating,the complete unit will stop operation.	Replace outdoor control panel AP1
49	Frequency limiting (power)						OFF 1S and blink 13 times			
50	Compressor running						OFF 1S and blink once			
51	The temperature for turning on the unit is reached						OFF 1S and blink 8 times			
52	Frequency limiting (module temperature)						OFF 1S and blink 11 times			

NO.	Malfunction Name	Display Method of Indoor Unit			Display Method of Outdoor Unit			A/C status	Possible Causes	
		Dual-8 Code Display	Indicator Display (during blinking, ON 0.5s and OFF 0.5s)			Indicator has 3 kinds of display status and during blinking, ON 0.5s and OFF 0.5s				
			Operation Indicator	Cool Indicator	Heating Indicator	Yellow Indicator	Red Indicator	Green Indicator		
53	Normal communication							OFF 0.5S and blink once		
54	Defrosting				OFF 3S and blink once (during blinking, ON 10s and OFF 0.5s)	OFF 1S and blink twice			Defrosting will occur in heating mode. Compressor will operate while indoor fan will stop operation.	Its the normal state

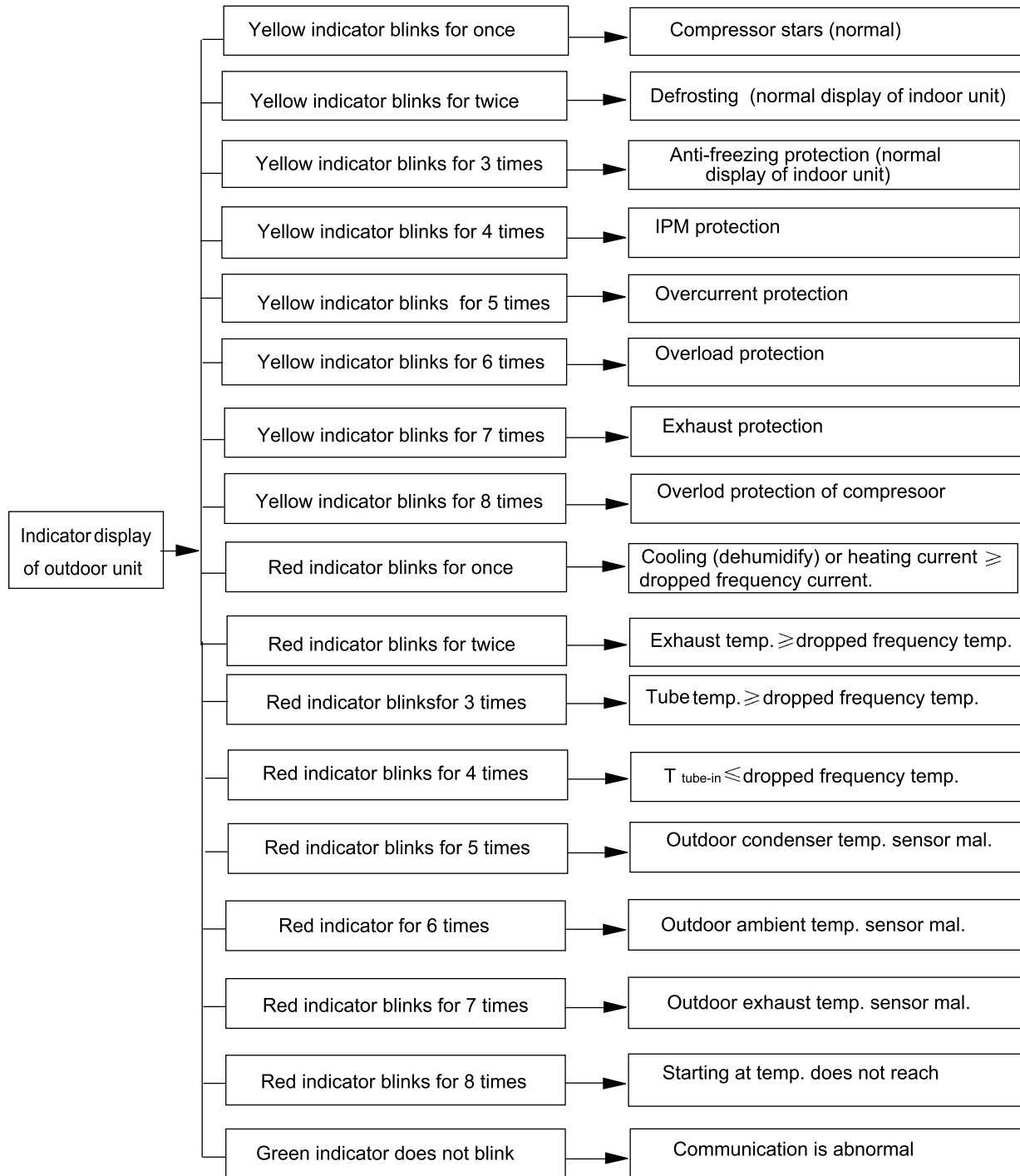

Analysis or processing of some of the malfunction display:

1. Compressor discharge protection

Possible reasons: shortage of refrigerant; blockage of air filter; poor ventilation or air flow short pass for condenser; the system has noncondensing gas (such as air, water etc.); blockage of capillary assy (including filter); leakage inside four-way valve causes incorrect operation; malfunction of compressor; malfunction of protection relay; malfunction of discharge sensor; outdoor temperature too high.

Processing method: refer to the malfunction analysis in the above section.

2. Low voltage overcurrent protection

Possible reason: Sudden drop of supply voltage.

3. Communication malfunction

Processing method: Check if communication signal cable is connected reliably.

4. Sensor open or short circuit

Processing method: Check whether sensor is normal, connected with the corresponding position on the controller and if damage of lead wire is found.

5. Compressor over load protection

Possible reasons: insufficient or too much refrigerant; blockage of capillary and increase of suction temp.; improper running of compressor, burning in or stuck of bearing, damage of discharge valve; malfunction of protector.

Processing method: adjust refrigerant amount; replace the capillary; replace the compressor; use universal meter to check if the contactor of compressor is fine when it is not overheated, if not replace the protector.

6. System malfunction

Overload protection. When tube temperature (Check the temperature of outdoor heat exchanger when cooling and check the temperature of indoor heat exchanger when heating) is too high, protection will be activated.

Possible reasons: Outdoor temperature is too high when cooling; insufficient outdoor air circulation; refrigerant flow malfunction

Please refer to the malfunction analysis in the previous section for handling method.

7. IPM module protection

Processing method: Once the module malfunction happens, if it persists for a long time and can not be self-canceled, cut off the power and turn off the unit, and then re-energize the unit again after about 10 min. After repeating the procedure for several times, if the malfunction still exists, replace the module.

9.2 How to Check Simply the Main Part

Indoor unit

1. Malfunction of Temperature Sensor F1, F2

Main detection points:

- Is the wiring terminal between the temperature sensor and the controller loosened or poorly contacted?
- Is there short circuit due to trip-over of the parts?
- Is the temperature sensor broken?
- Is mainboard broken?

Malfunction diagnosis process:

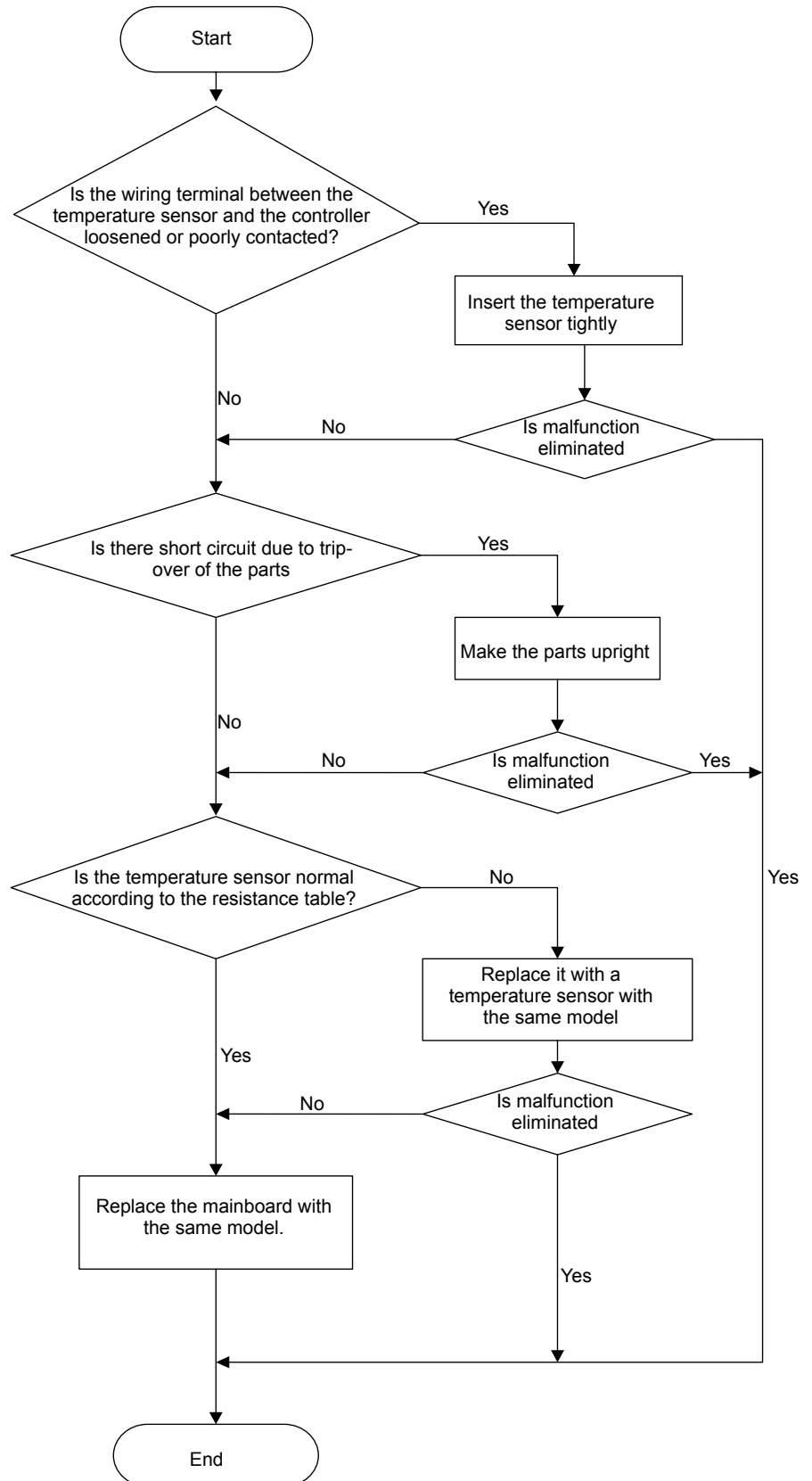

2. Malfunction of Blocked Protection of IDU Fan Motor H6

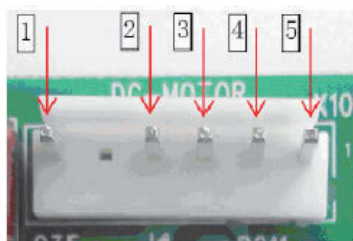
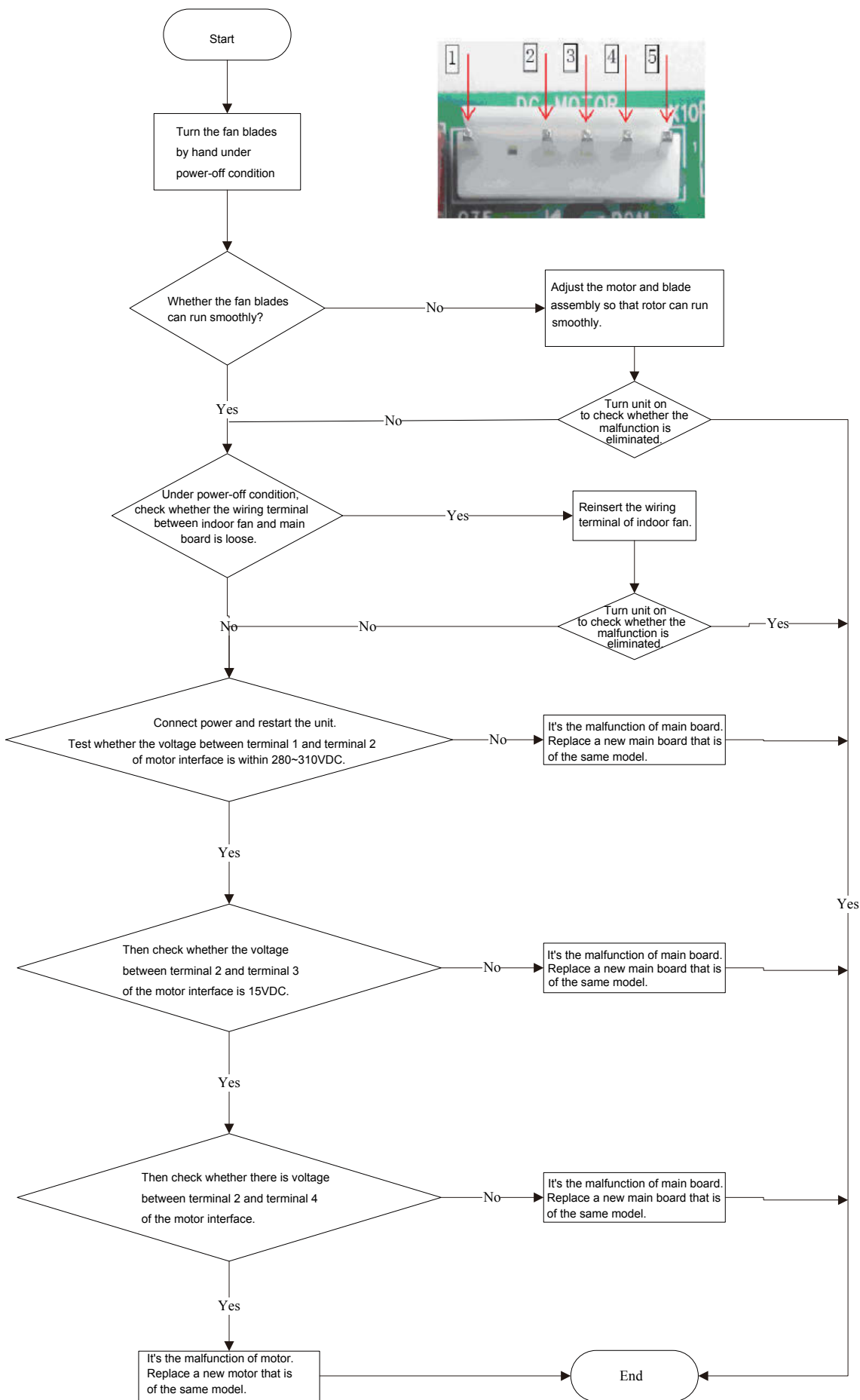

3. Malfunction of Protection of Jumper Cap C5

Main detection points:

- Is there jumper cap on the mainboard?
- Is the jumper cap inserted correctly and tightly?
- The jumper is broken?
- The motor is broken?
- Detection circuit of the mainboard is defined abnormal

Malfunction diagnosis process:

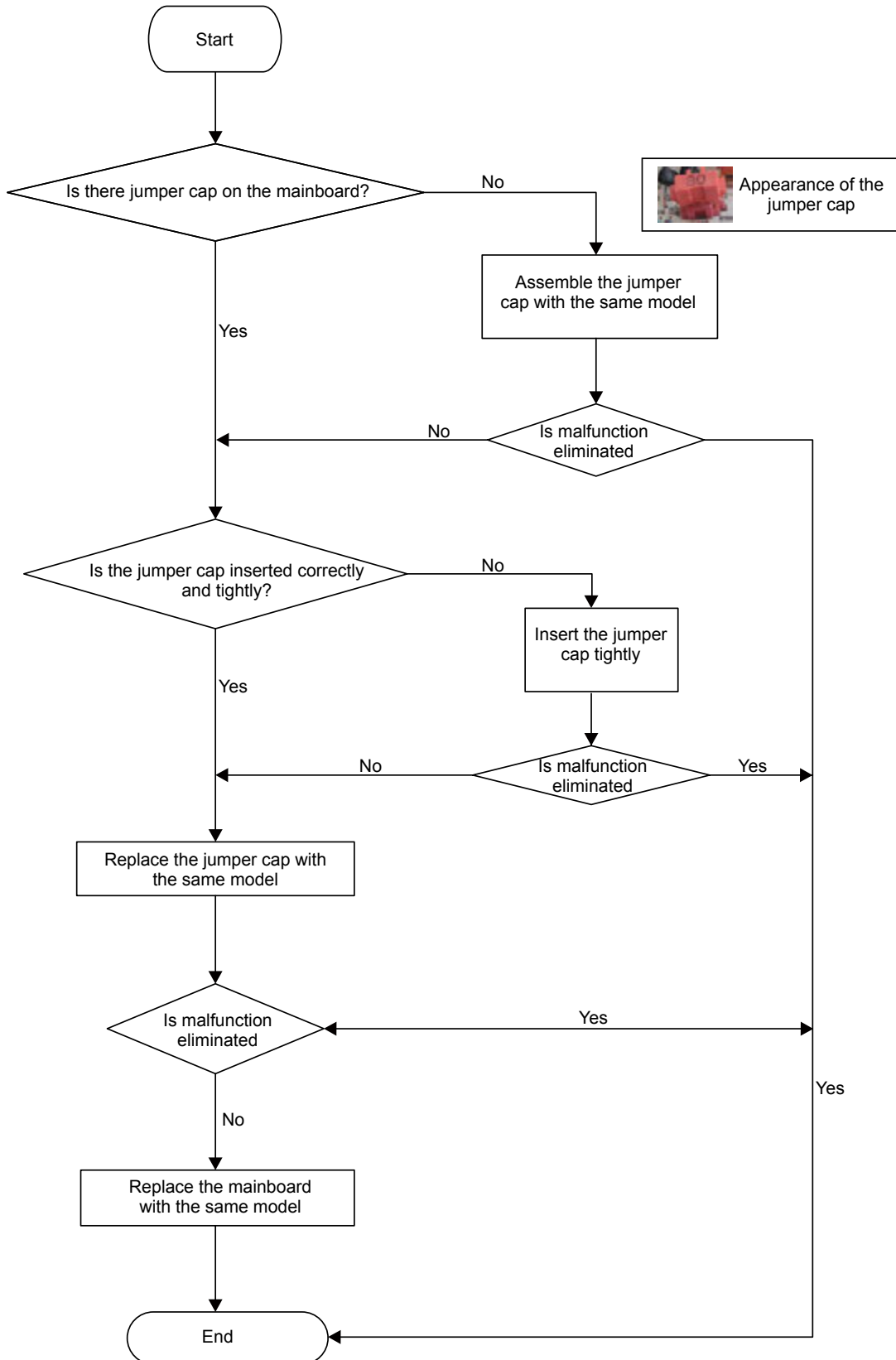

4. Malfunction of Overcurrent Protection E5

Main detection points:

- Is the supply voltage unstable with big fluctuation
- Is the supply voltage too low with overload?
- Hardware trouble?

Malfunction diagnosis process:

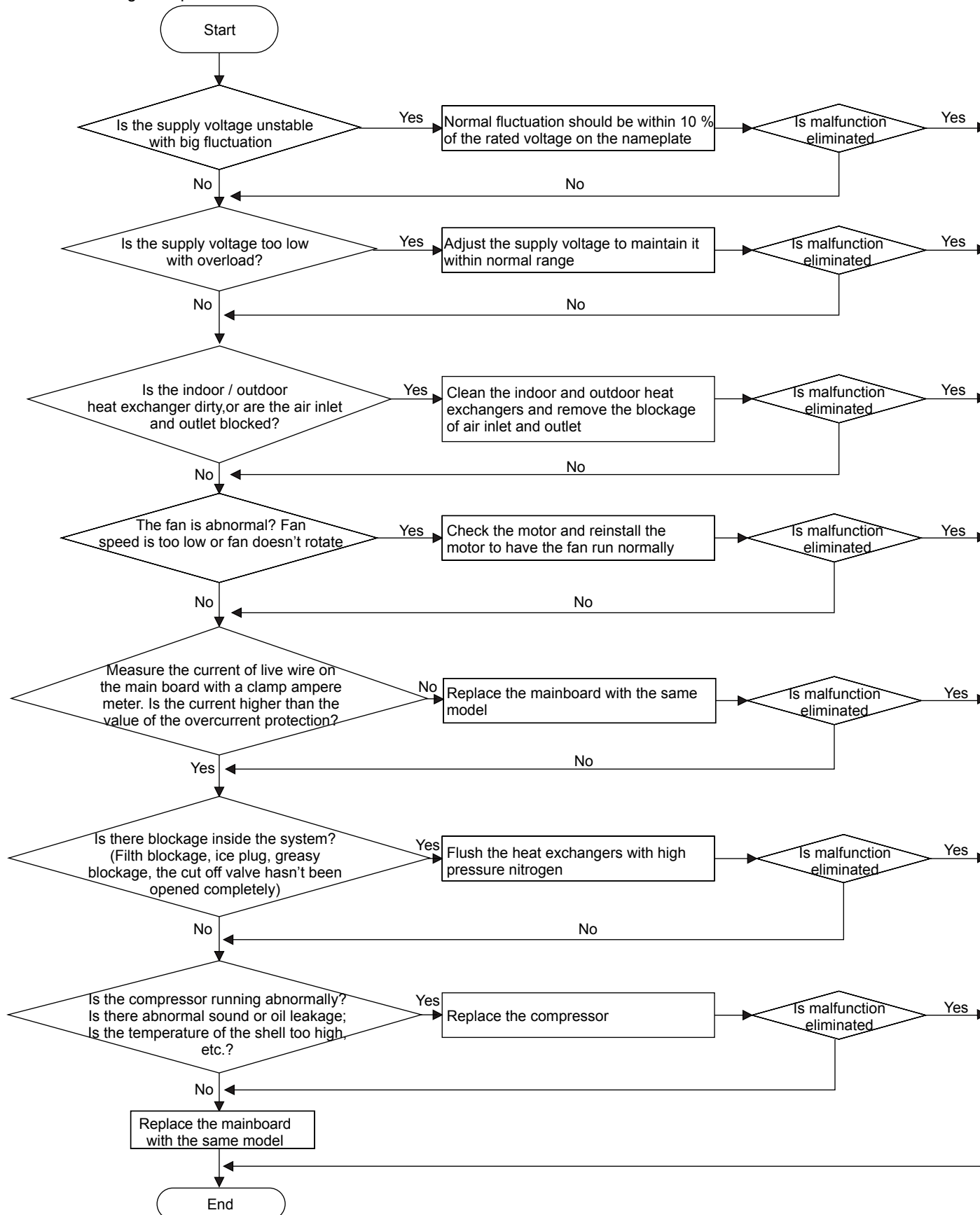

5. Malfunction of Zero-crossing Inspection Circuit Malfunction of the IDU Fan Motor U8

Main detection points:

- Instant energization after de-energization while the capacitor discharges slowly?
- The zero-cross detection circuit of the mainboard is defined abnormal

Malfunction diagnosis process:

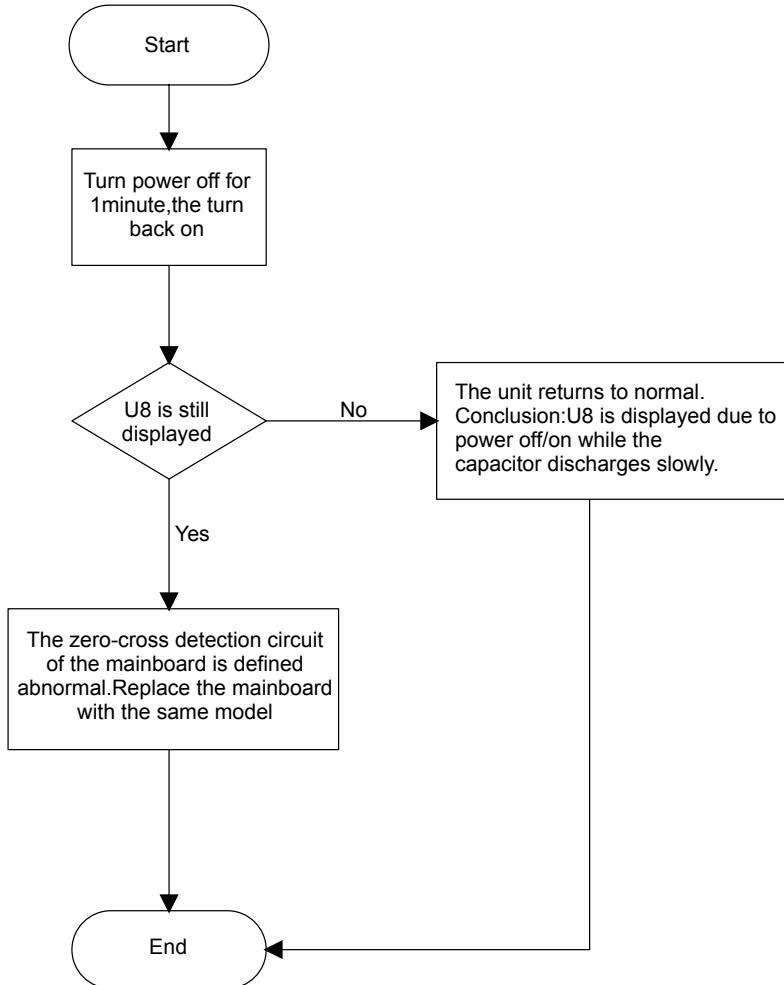

6. Malfunction of communication E6

Main detection points:

- Check if the connection wire and the built-in wiring of indoor and outdoor unit are connected well and without damage;
- If the communication circuit of indoor mainboard is damaged? If the communication circuit of outdoor mainboard (AP1) is damaged?

Malfunction diagnosis process:

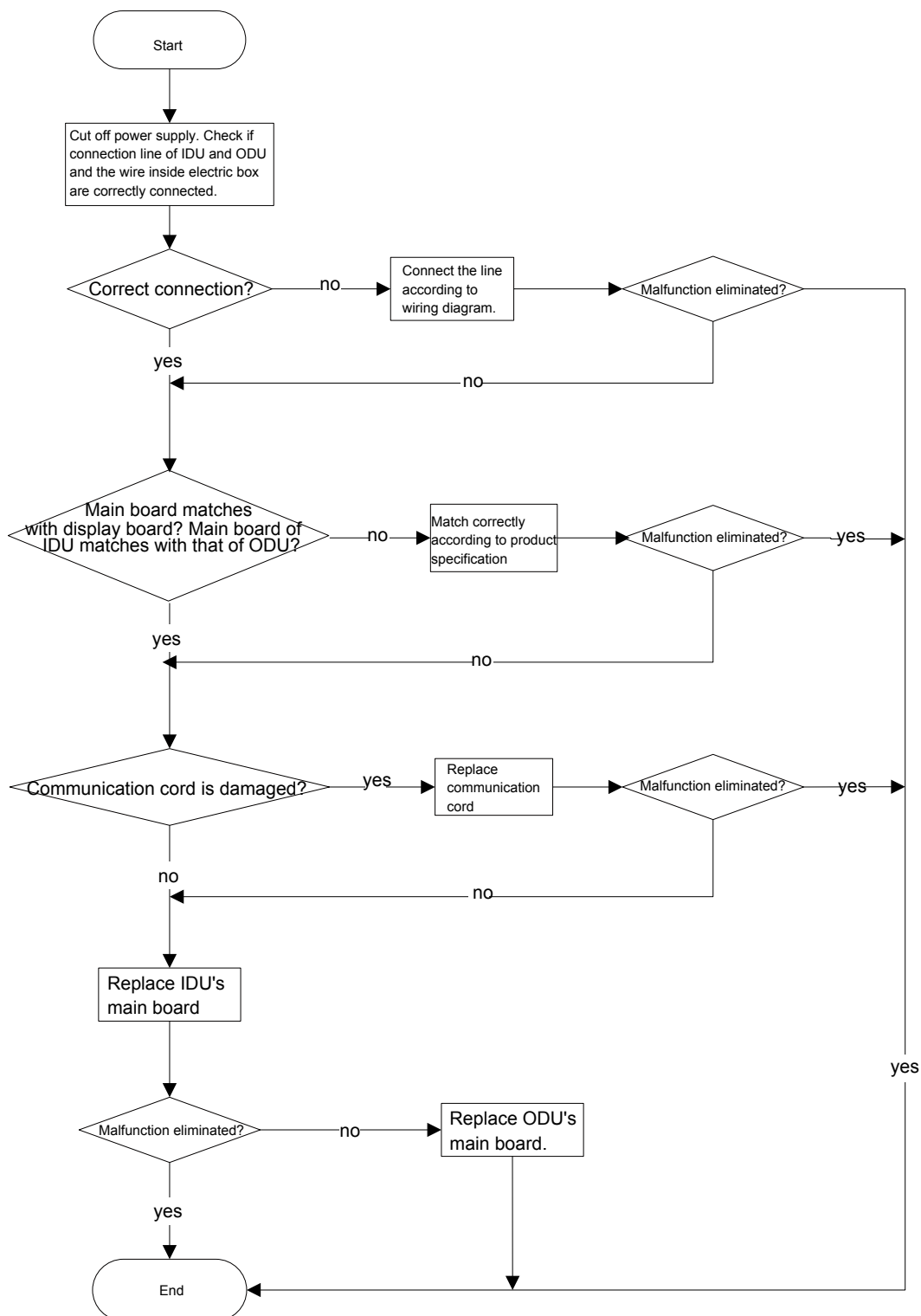

Outdoor unit

(1) Capacitor charge fault (Fault with outdoor unit) (AP1 below refers to the outdoor control panel)

Main Check Points:

- Use AC voltmeter to check if the voltage between terminal L and N on the wiring board is within 210VAC~240VAC.
- If the reactor (L) is correctly connected? If the connection is loose or fallen? If the reactor (L) is damaged?

Fault diagnosis process:

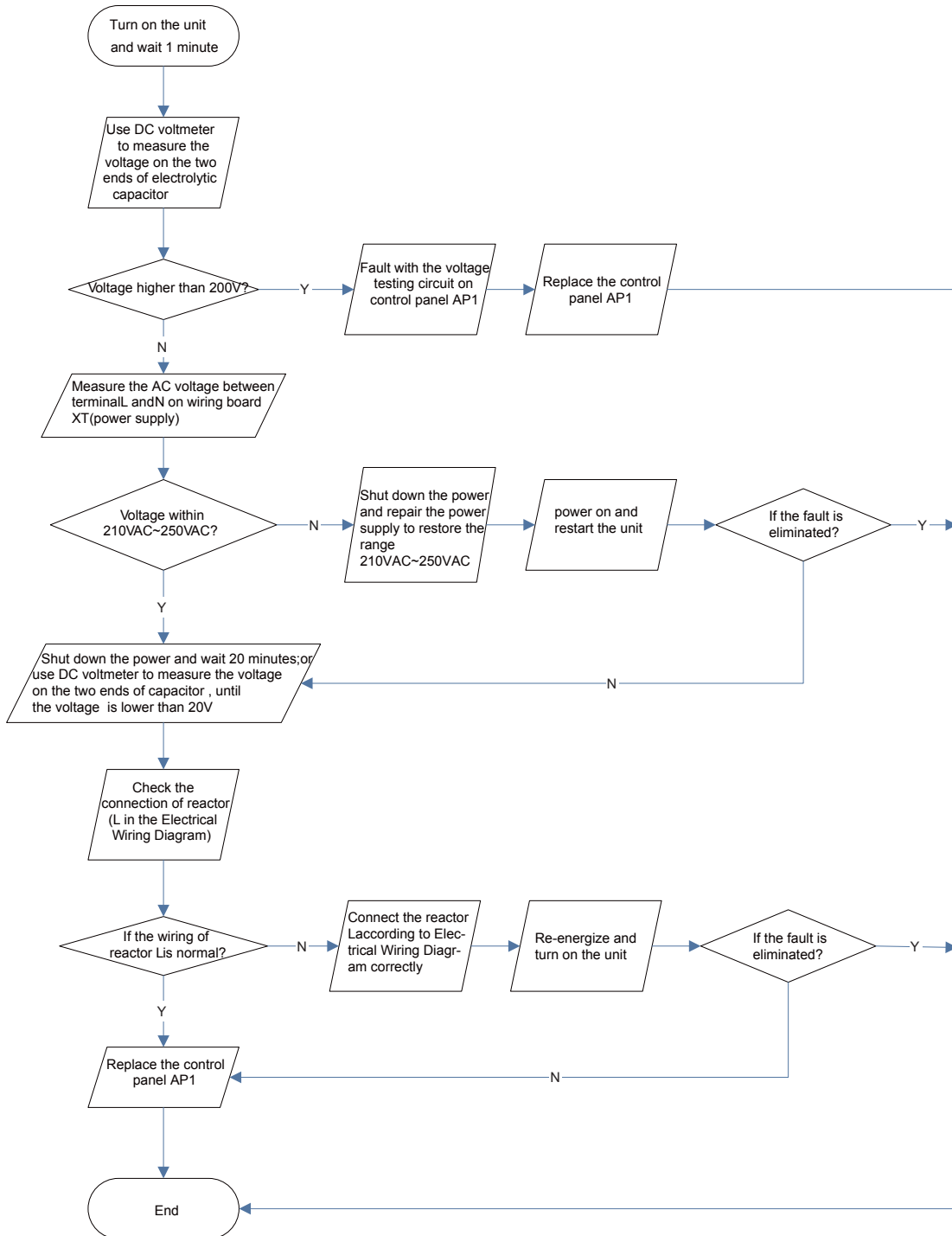

(2) IPM Protection, Out-of-step Fault, Compressor Phase Overcurrent (AP1 below refers to the outdoor control panel)

Main check points:

- If the connection between control panel AP1 and compressor COMP is secure? If loose? If the connection is in correct order?
- If the voltage input of the machine is within normal range? (Use AC voltmeter to measure the voltage between terminal L and N on the wiring board XT)
- If the compressor coil resistance is normal? If the insulation of compressor coil against the copper tube is in good condition?
- If the working load of the machine are too high? If the radiation is good?
- If the charge volume of refrigerant is correct?

Fault diagnosis process:

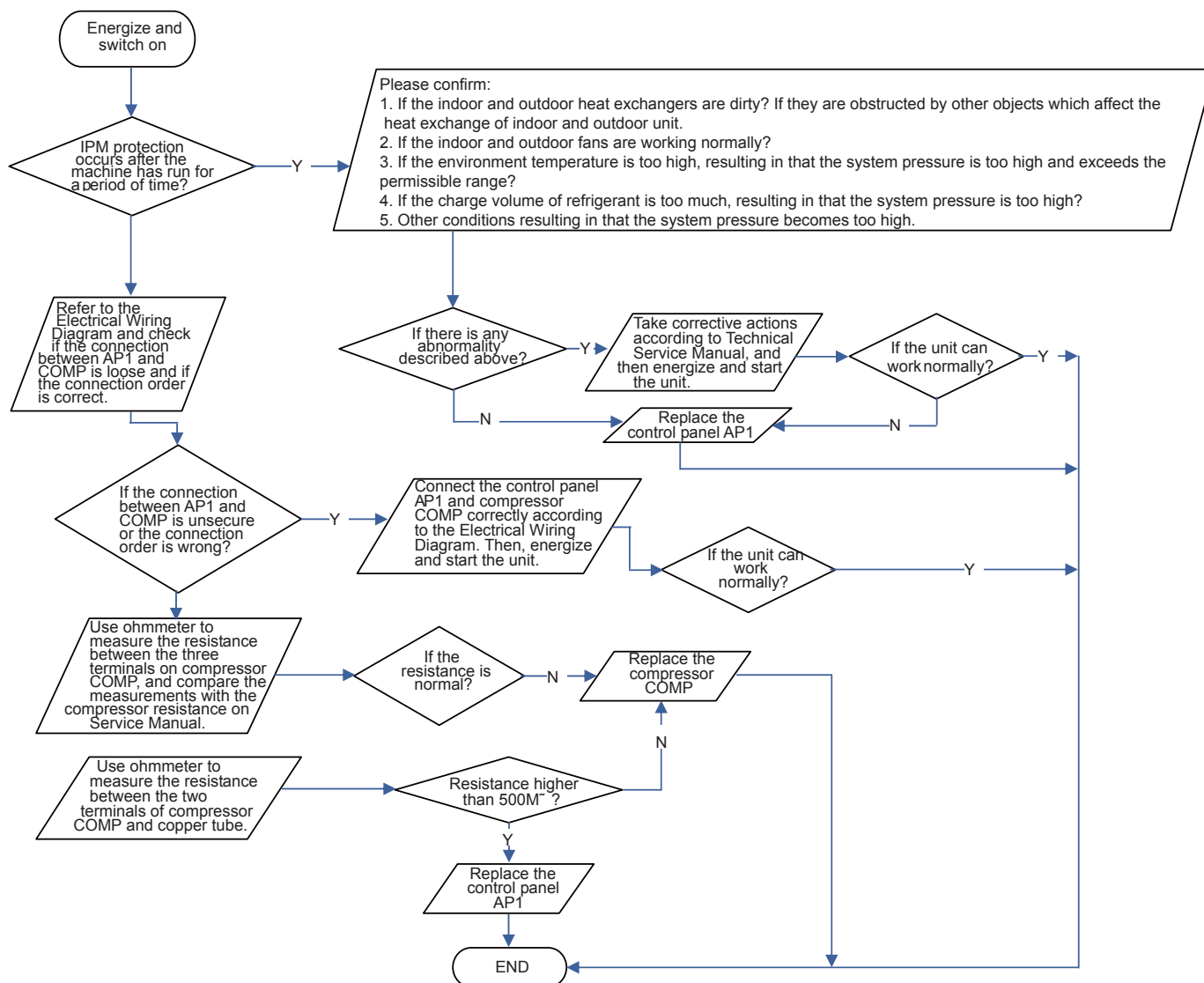

(3) High temperature and overload protection diagnosis (AP1 hereinafter refers to the control board of the outdoor unit)

Mainly detect:

- Is outdoor ambient temperature in normal range?
- Are the outdoor and indoor fans operating normally?
- Is the heat dissipation environment inside and outside the unit is good?

Fault diagnosis process:

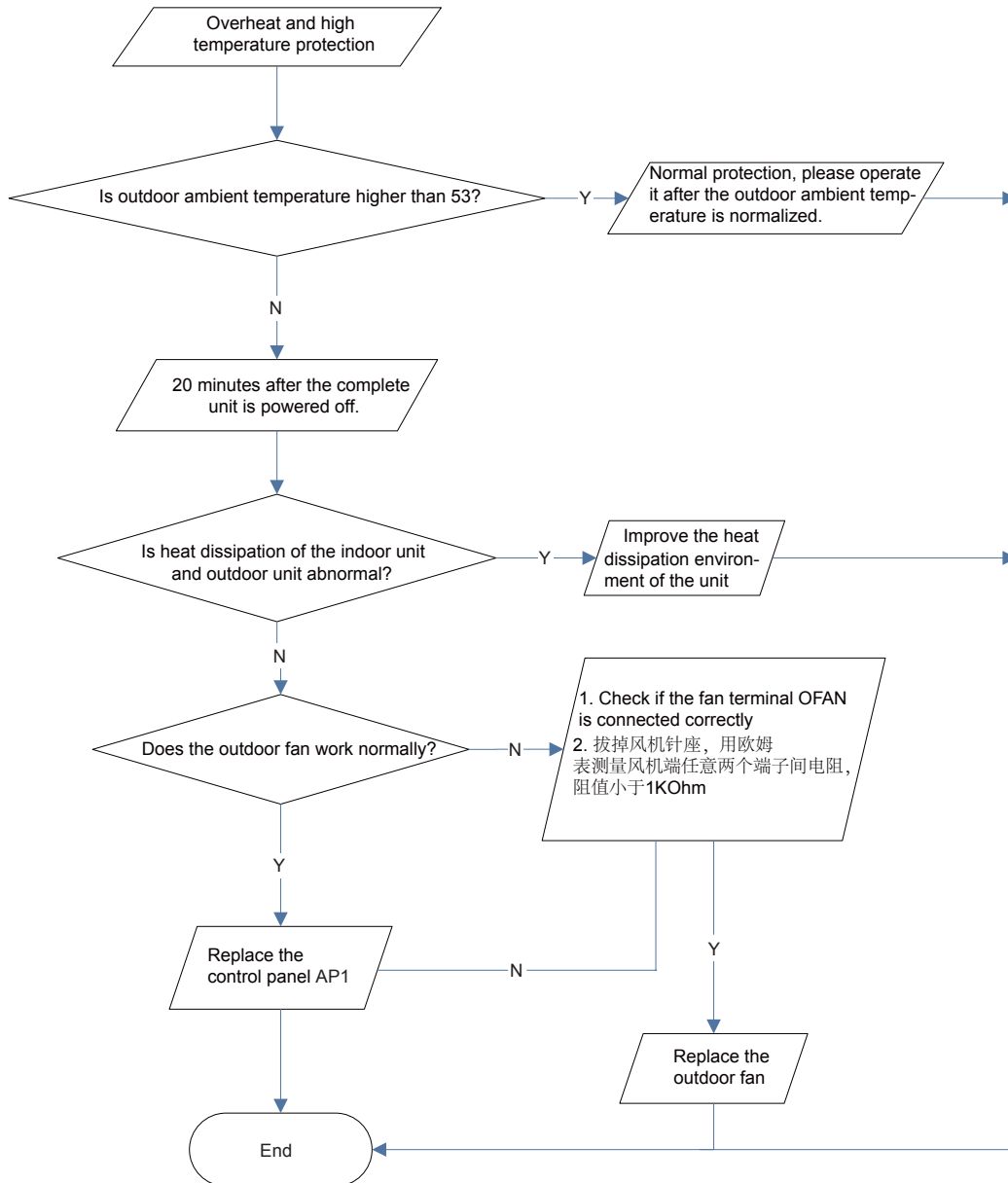

(4) Start-up failure (following AP1 for outdoor unit control board)

Mainly detect:

- Whether the compressor wiring is connected correct?
- Is compressor broken?
- Is time for compressor stopping enough?

Fault diagnosis process:

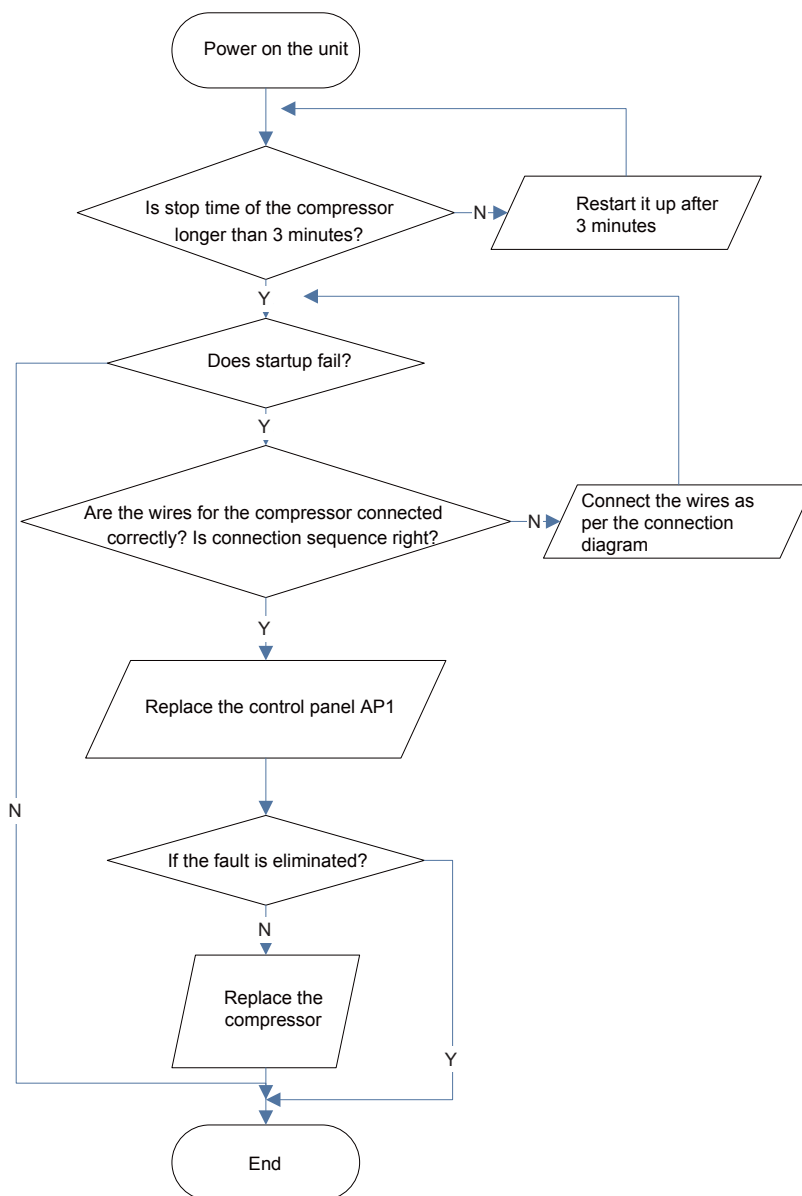

(5) Out of step diagnosis for the compressor (AP1 hereinafter refers to the control board of the outdoor unit)

Mainly detect:

- Whether the system pressure is too high?
- Whether the input voltage is too low?

Fault diagnosis process:

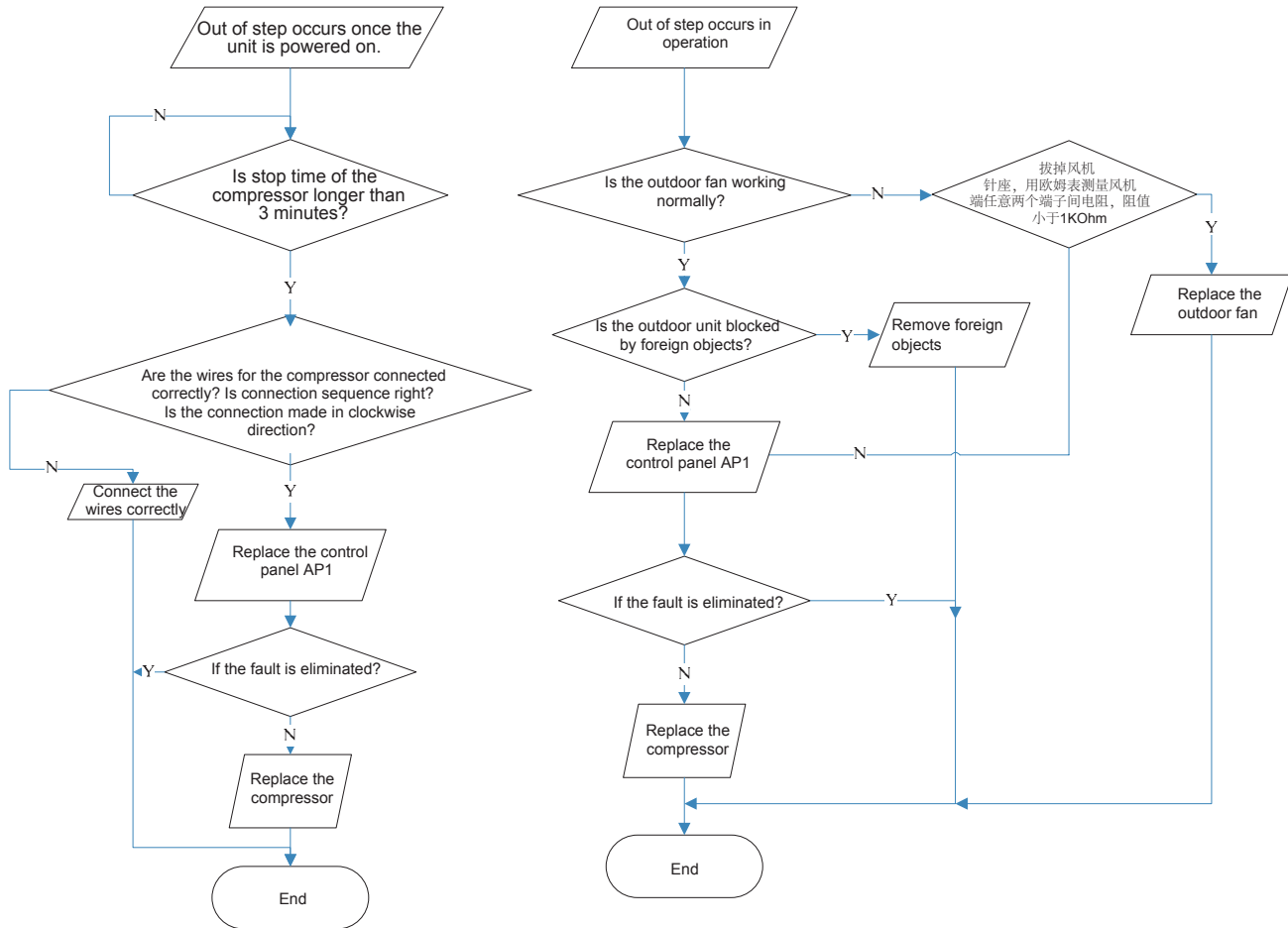

(6) Overload and air exhaust malfunction diagnosis (following AP1 for outdoor unit control board)

Mainly detect:

- Whether the PMV is connected well or not? Is PMV damaged?
- Is refrigerant leaked?

Fault diagnosis process:

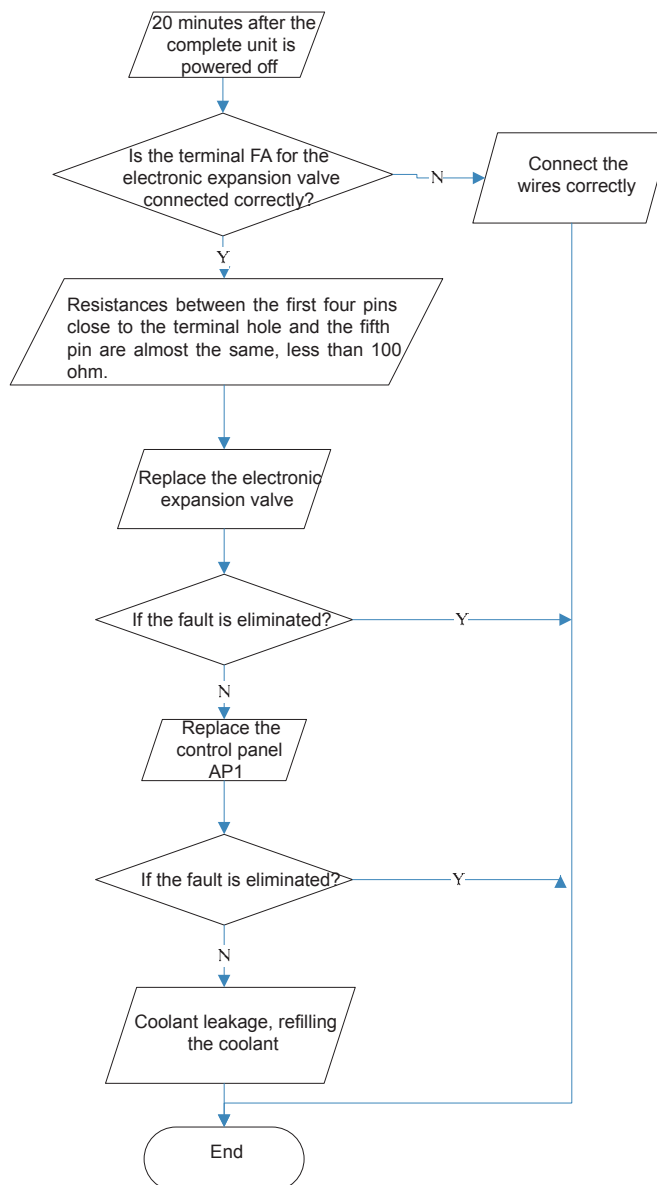

(7) Power factor correct or (PFC) fault (a fault of outdoor unit) (AP1 hereinafter refers to the control board of the outdoor unit)

Mainly detect:

- Check if the reactor (L) of the outdoor unit and the PFC capacitor are broken

Fault diagnosis process:

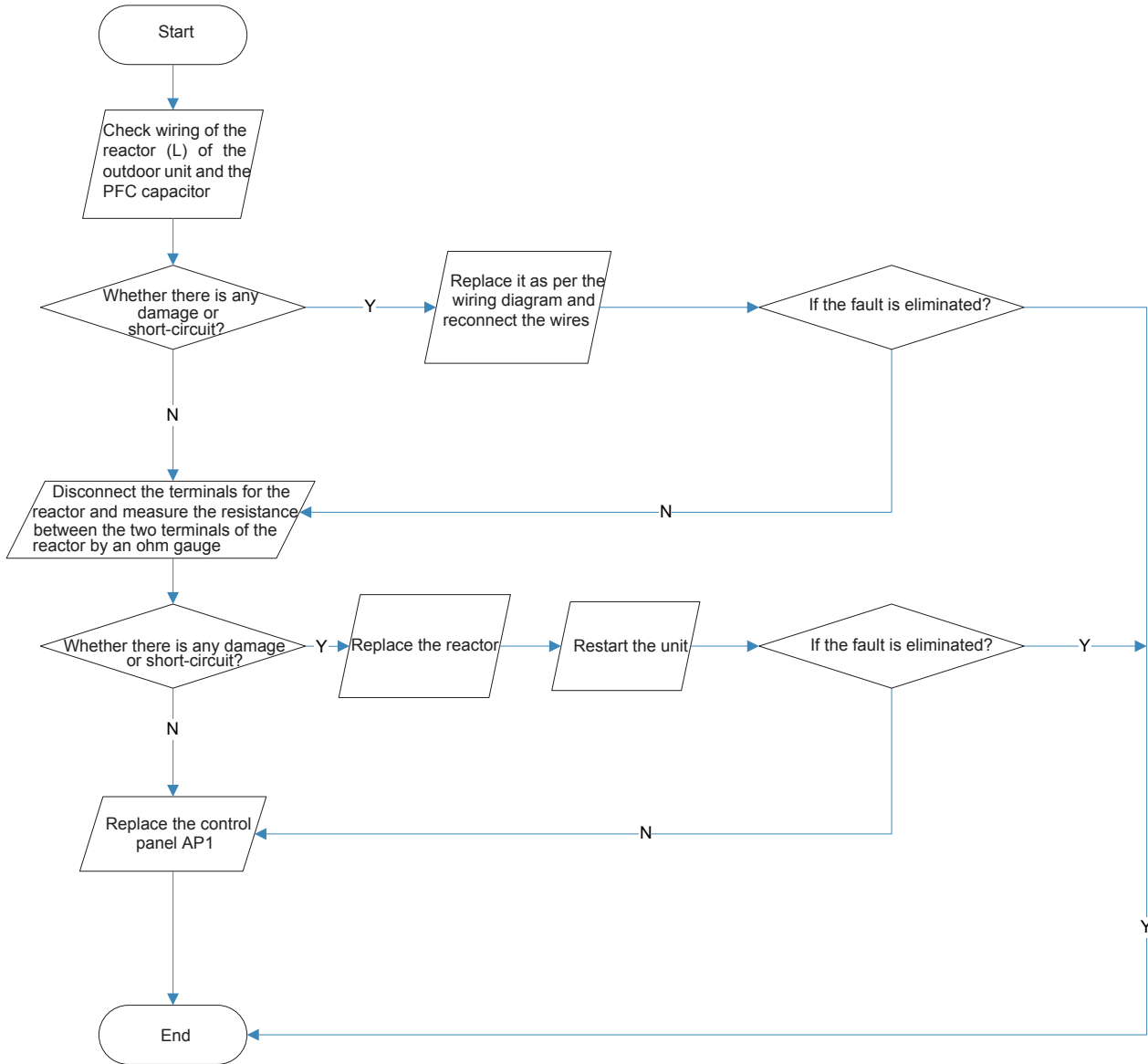

(8) Communication malfunction: (following AP1 for outdoor unit control board)

Mainly detect:

- Is there any damage for the indoor unit mainboard communication circuit? Is communication circuit damaged?
- Detect the indoor and outdoor units connection wire and indoor and outdoor units inside wiring is connect well or not, if is there any damage?

Fault diagnosis process:

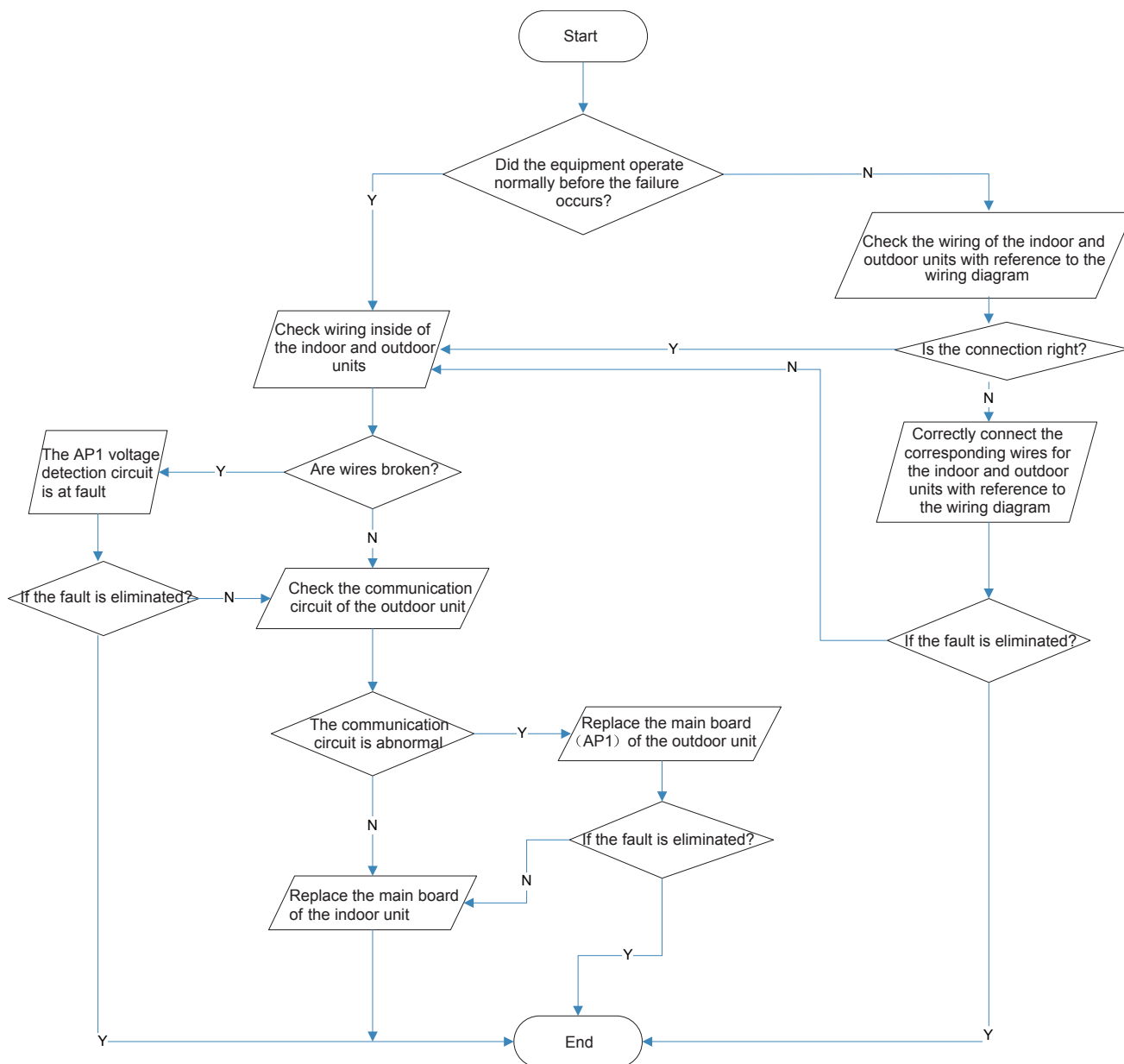

(9) Communication malfunction:(following AP1 for outdoor unit control board)

Mainly detect:

Detect the indoor and outdoor units connection wire and indoor and outdoor units inside wiring is connect well or not, If is there any damage?

Is there any damage for the indoor unit mainboard communication circuit? Is communication circuit damaged?

The flow chart fir malfunction detect:



(10) High-pressure Protection

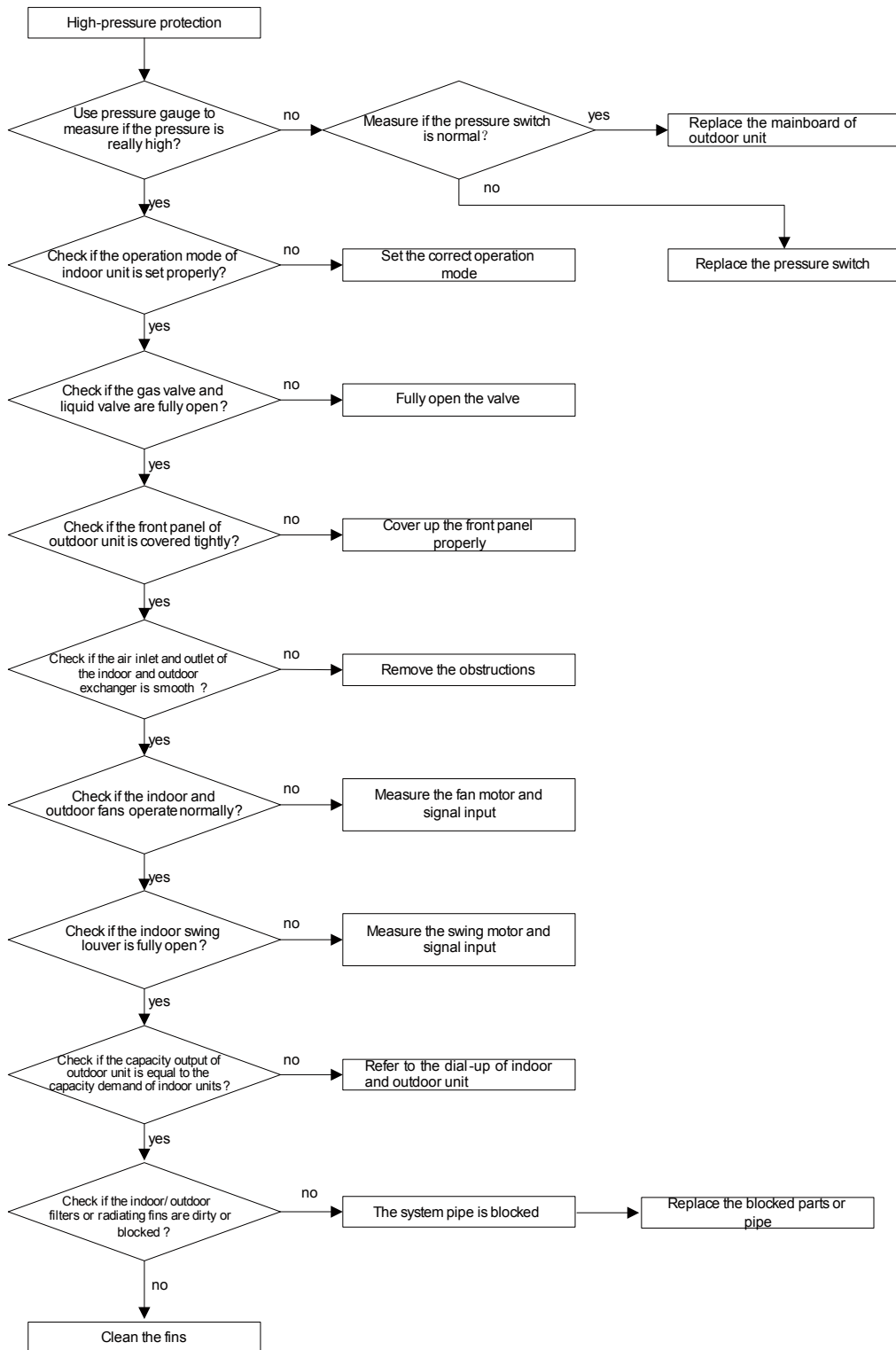

9.3 Troubleshooting for Normal Malfunction

1. Air Conditioner Can't be Started up

Possible Causes	Discriminating Method (Air conditioner Status)	Troubleshooting
No power supply, or poor connection for power plug	After energization, operation indicator isn't bright and the buzzer can't give out sound	Confirm whether it's due to power failure. If yes, wait for power recovery. If not, check power supply circuit and make sure the power plug is connected well.
Wrong wire connection between indoor unit and outdoor unit, or poor connection for wiring terminals	Under normal power supply circumstances, operation indicator isn't bright after energization	Check the circuit according to circuit diagram and connect wires correctly. Make sure all wiring terminals are connected firmly
Electric leakage for air conditioner	After energization, room circuit breaker trips off at once	Make sure the air conditioner is grounded reliably Make sure wires of air conditioner is connected correctly Check the wiring inside air conditioner. Check whether the insulation layer of power cord is damaged; if yes, place the power cord.
Model selection for air switch is improper	After energization, air switch trips off	Select proper air switch
Malfunction of remote controller	After energization, operation indicator is bright, while no display on remote controller or buttons have no action.	Replace batteries for remote controller Repair or replace remote controller

2. Poor Cooling (heating) for Air Conditioner

Possible Causes	Discriminating Method (Air conditioner Status)	Troubleshooting
Set temperature is improper	Observe the set temperature on remote controller	Adjust the set temperature
Rotation speed of the IDU fan motor is set too low	Small wind blow	Set the fan speed at high or medium
Filter of indoor unit is blocked	Check the filter to see it's blocked	Clean the filter
Installation position for indoor unit and outdoor unit is improper	Check whether the installation position is proper according to installation requirement for air conditioner	Adjust the installation position, and install the rainproof and sunproof for outdoor unit
Refrigerant is leaking	Discharged air temperature during cooling is higher than normal discharged wind temperature; Discharged air temperature during heating is lower than normal discharged wind temperature; Unit's pressure is much lower than regulated range	Find out the leakage causes and deal with it. Add refrigerant.
Malfunction of 4-way valve	Blow cold wind during heating	Replace the 4-way valve
Malfunction of capillary	Discharged air temperature during cooling is higher than normal discharged wind temperature; Discharged air temperature during heating is lower than normal discharged wind temperature; Unit's pressure is much lower than regulated range. If refrigerant isn't leaking, part of capillary is blocked	Replace the capillary
Flow volume of valve is insufficient	The pressure of valves is much lower than that stated in the specification	Open the valve completely
Malfunction of horizontal louver	Horizontal louver can't swing	Refer to point 3 of maintenance method for details
Malfunction of the IDU fan motor	The IDU fan motor can't operate	Refer to troubleshooting for H6 for maintenance method in details
Malfunction of the ODU fan motor	The ODU fan motor can't operate	Refer to point 4 of maintenance method for details
Malfunction of compressor	Compressor can't operate	Refer to point 5 of maintenance method for details

3. Horizontal Louver Can't Swing

Possible Causes	Discriminating Method (Air conditioner Status)	Troubleshooting
Wrong wire connection, or poor connection	Check the wiring status according to circuit diagram	Connect wires according to wiring diagram to make sure all wiring terminals are connected firmly
Stepping motor is damaged	Stepping motor can't operate	Repair or replace stepping motor
Main board is damaged	Others are all normal, while horizontal louver can't operate	Replace the main board with the same model

4. ODU Fan Motor Can't Operate

Possible causes	Discriminating method (air conditioner status)	Troubleshooting
Wrong wire connection, or poor connection	Check the wiring status according to circuit diagram	Connect wires according to wiring diagram to make sure all wiring terminals are connected firmly
Capacity of the ODU fan motor is damaged	Measure the capacity of fan capacitor with an universal meter and find that the capacity is out of the deviation range indicated on the nameplate of fan capacitor.	Replace the capacity of fan
Power voltage is a little low or high	Use universal meter to measure the power supply voltage. The voltage is a little high or low	Suggest to equip with voltage regulator
Motor of outdoor unit is damaged	When unit is on, cooling/heating performance is bad and ODU compressor generates a lot of noise and heat.	Change compressor oil and refrigerant. If no better, replace the compressor with a new one

5. Compressor Can't Operate

Possible causes	Discriminating method (air conditioner status)	Troubleshooting
Wrong wire connection, or poor connection	Check the wiring status according to circuit diagram	Connect wires according to wiring diagram to make sure all wiring terminals are connected firmly
Capacity of compressor is damaged	Measure the capacity of fan capacitor with an universal meter and find that the capacity is out of the deviation range indicated on the nameplate of fan capacitor.	Replace the compressor capacitor
Power voltage is a little low or high	Use universal meter to measure the power supply voltage. The voltage is a little high or low	Suggest to equip with voltage regulator
Coil of compressor is burnt out	Use universal meter to measure the resistance between compressor terminals and it's 0	Repair or replace compressor
Cylinder of compressor is blocked	Compressor can't operate	Repair or replace compressor

6. Air Conditioner is Leaking

Possible causes	Discriminating method (air conditioner status)	Troubleshooting
Drain pipe is blocked	Water leaking from indoor unit	Eliminate the foreign objects inside the drain pipe
Drain pipe is broken	Water leaking from drain pipe	Replace drain pipe
Wrapping is not tight	Water leaking from the pipe connection place of indoor unit	Wrap it again and bundle it tightly

7. Abnormal Sound and Vibration

Possible causes	Discriminating method (air conditioner status)	Troubleshooting
When turn on or turn off the unit, the panel and other parts will expand and there's abnormal sound	There's the sound of "PAPA"	Normal phenomenon. Abnormal sound will disappear after a few minutes.
When turn on or turn off the unit, there's abnormal sound due to flow of refrigerant inside air conditioner	Water-running sound can be heard	Normal phenomenon. Abnormal sound will disappear after a few minutes.
Foreign objects inside the indoor unit or there're parts touching together inside the indoor unit	There's abnormal sound fro indoor unit	Remove foreign objects. Adjust all parts' position of indoor unit, tighten screws and stick damping plaster between connected parts
Foreign objects inside the outdoor unit or there're parts touching together inside the outdoor unit	There's abnormal sound fro outdoor unit	Remove foreign objects. Adjust all parts' position of outdoor unit, tighten screws and stick damping plaster between connected parts
Short circuit inside the magnetic coil	During heating, the way valve has abnormal electromagnetic sound	Replace magnetic coil
Abnormal shake of compressor	Outdoor unit gives out abnormal sound	Adjust the support foot mat of compressor, tighten the bolts
Abnormal sound inside the compressor	Abnormal sound inside the compressor	If add too much refrigerant during maintenance, please reduce refrigerant properly. Replace compressor for other circumstances.

10. Exploded View and Parts List

10.1 Indoor Unit

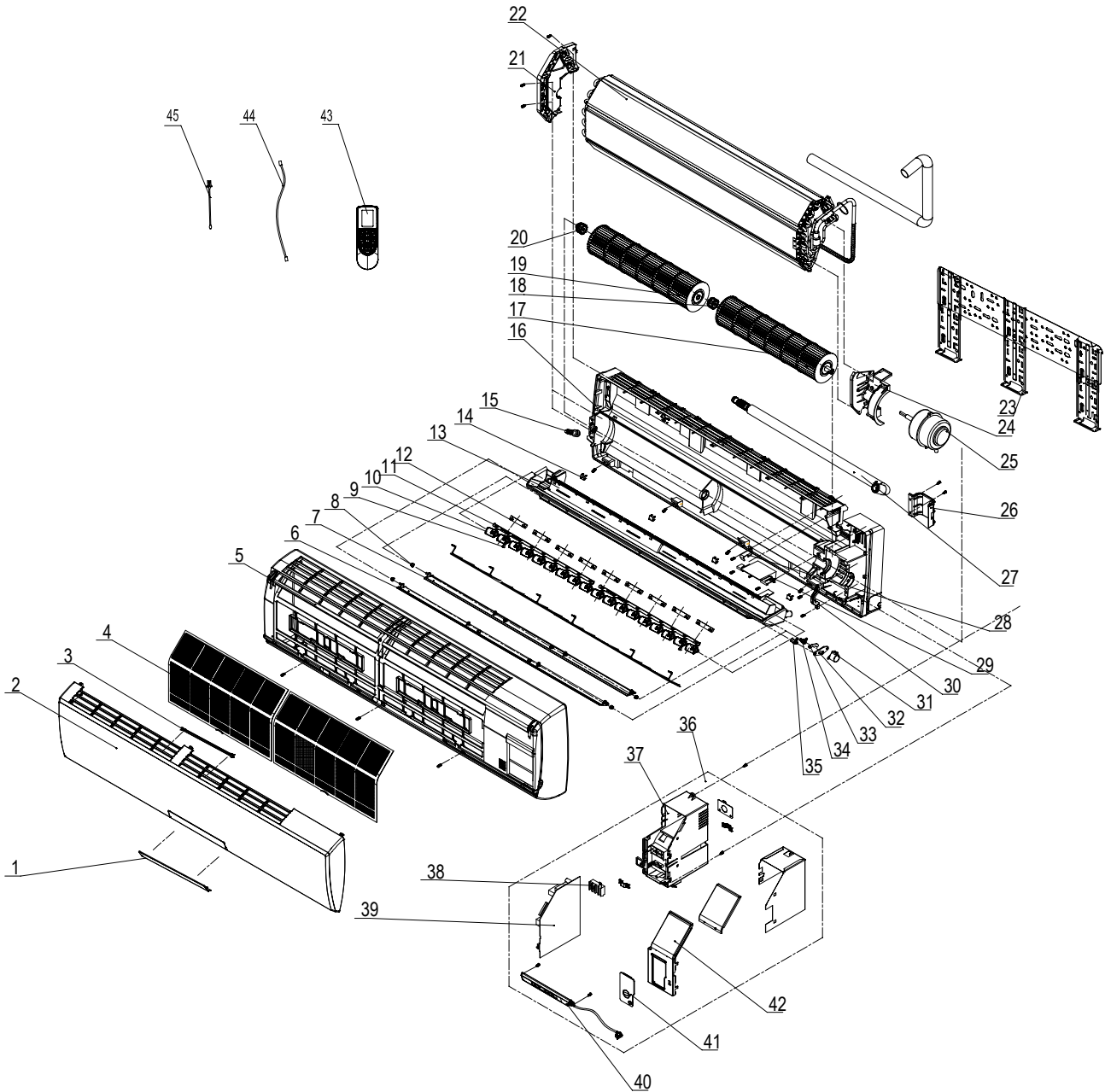

NO.	Description	Part Code		Qty
		IAC36LB-D3DNA3D/I	IAH36LB-D3DNA3D/I	
1	Receiver Window	22432164	22432164	1
2	Front Panel	20012490S	20012490S	1
3	Stand bar	24212120	24212120	1
4	Filter Sub-Assy	11122106	11122106	2
5	Front Case Sub-Assy	20022159	20022159	1
6	Upper Guide Louver	10512166	10512166	1
7	Lower guide louver	10512167	10512167	1
8	Axile Bush	10542704	10542704	6
9	Air Louver 2	10512169	10512169	2
10	Air Louver 1	10512168	10512168	16
11	Connecting Rod	10582086	10582086	2
12	Louver Clamp	26112158	26112158	9
13	Water Tray	20182138	20182138	1
14	Screw Cover	242520053	242520053	4
15	Rubber Plug (Water Tray)	76712012	76712012	1
16	Rear Case Sub-Assy	22202928	22202928	1
17	Cross Flow Fan 1	10352039	10352039	1
18	Bearing Holder sub-assy	26152028	26152028	1
19	Cross Flow Fan 2	10352040	10352040	1
20	O-Gasket sub-assy of Bearing	76512051	76512051	1
21	Left Evaporator Support	24212041	24212041	1
22	Evaporator Assy	01002000027	01002000027	1
23	Wall Mounting Frame	01252398	01252398	1
24	Right Support of Evaporator	2421204201	2421204201	1
25	Fan Motor	1501213401	1501213401	1
26	Pipe Clamp	26112071	26112071	1
27	Drainage hose	0523001404	0523001404	1
28	Fixed Clip (Evaporator)	02112009	02112009	1
29	Cover Plate	20122124	20122124	1
30	Motor Fixed Clip	26112324	26112324	1
31	Step Motor	1521210701	1521210701	1
32	Press plate (crank)	26112070	26112070	1
33	Crank-guide	10582041	10582041	1
34	Upper Crank	10562004	10562004	1
35	Lower crank	10562005	10562005	1
36	Electric Box Assy	10000201768	10000201767	1
37	Electric Box	201022502	201022502	1
38	Terminal Board	4201123303	4201123303	1
39	Main Board	30138000687	30138000192	1
40	Display Board	30565087	30565087	1
41	Electric Box Cover	201022523	201022523	1
42	Electric Box Cover	2011204404S	2011204404S	1
43	Remote Controller	30510092	30510092	1
44	Tube Sensor	390000592	390000592	1
45	Ambient Temperature Sensor	390000453	390000453	1

Above data is subject to change without notice.

10.2 Outdoor Unit

IAC36LB-D3DNA3D

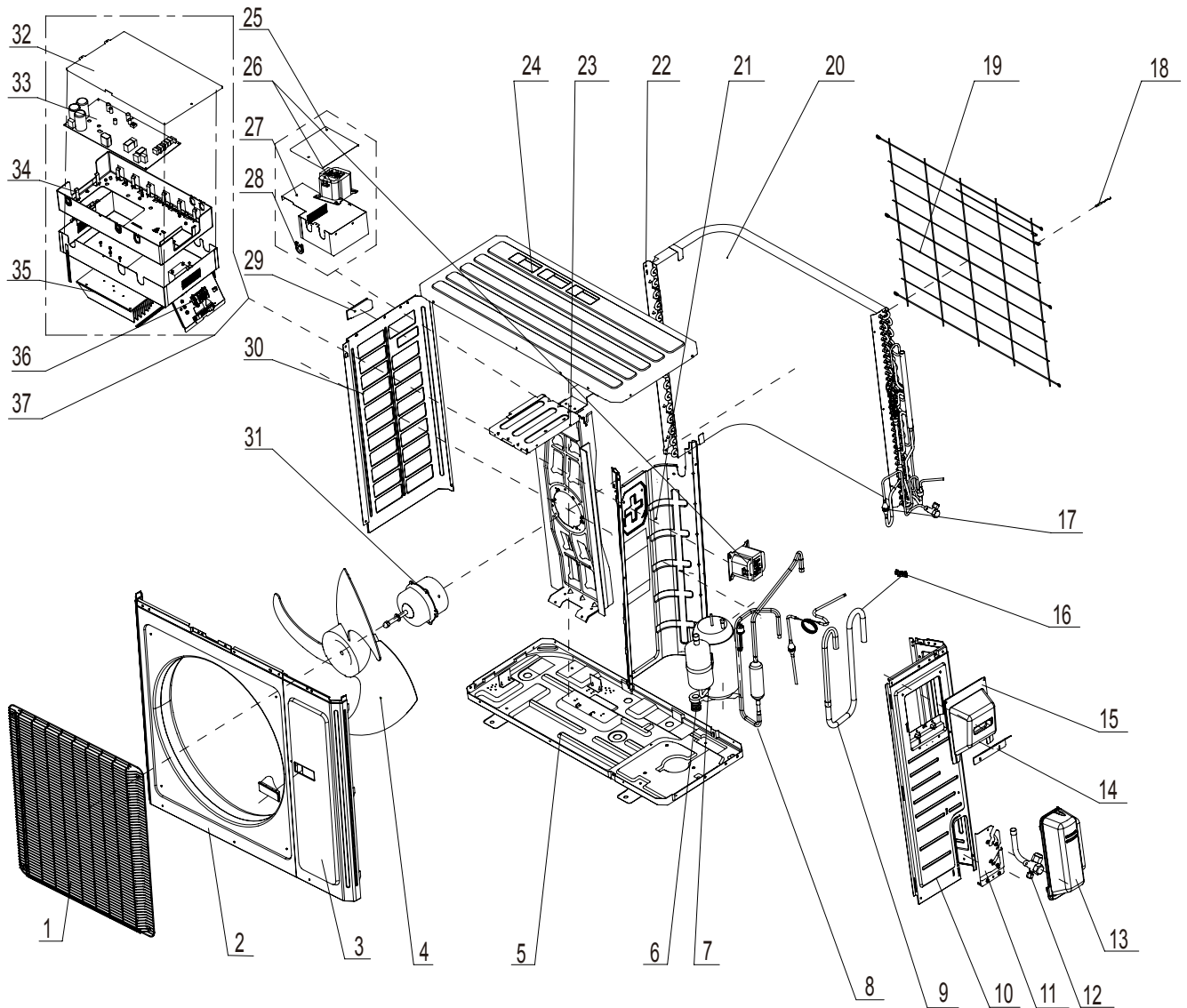

NO.	Description	Product Code	Qty
		IAC36LB-D3DNA3D	
Part Number		700482	
1	Front Grill	01473050	1
2	Cabinet	0143500401P	1
3	Front Side Plate	01303249P	1
4	Axial Flow Fan	10335014	1
5	Chassis Sub-assy	0280302601P	1
6	Compressor Gasket	76710207	3
7	Compressor and Fittings	00205275	1
8	Discharge Tube Sub-assy	03500600543	1
9	Inhalation Tube Sub-assy	03001000246	1
10	Right Side Plate	0130504402P	1
11	Valve Support Sub-Assy	0171501201P	1
12	Cut off Valve	07135054	1
13	Valve Cover	22245003	1
14	Retaining plate	02115006P	1
15	Handle assy	02113109	1
16	Wiring clamp	26115004	1
17	Electric Expansion Valve Sub-Assy	07133688	1
18	Temperature Sensor	3900031001	1
19	Rear Grill	01475013	1
20	Condenser Assy	0116349101	1
21	Clapboard	01233134	1
22	Condenser support plate	01175037	1
23	Motor Support Sub-Assy	0180287601	1
24	Top Cover Sub-Assy	01255007	1
25	Electric Box Cover	01425279	1
26	Reactor	43130192	2
27	Electric Box Sub-Assy	02603614	1
28	Pass wire ring sub-assy	76614102	2
29	left handle	26233053	1
30	Left Side Plate	01305043P	1
31	Fan Motor	1570280205	1
32	Electric Box Cover	01425281	1
33	Main Board	30138000712	1
34	Electric Box	02603614	1
35	Radiator	49013046	1
36	Terminal Board	4201025501	1
37	Electric Box Assy	10000100310	1

Above data is subject to change without notice.

IAH36LB-D3DNA3D

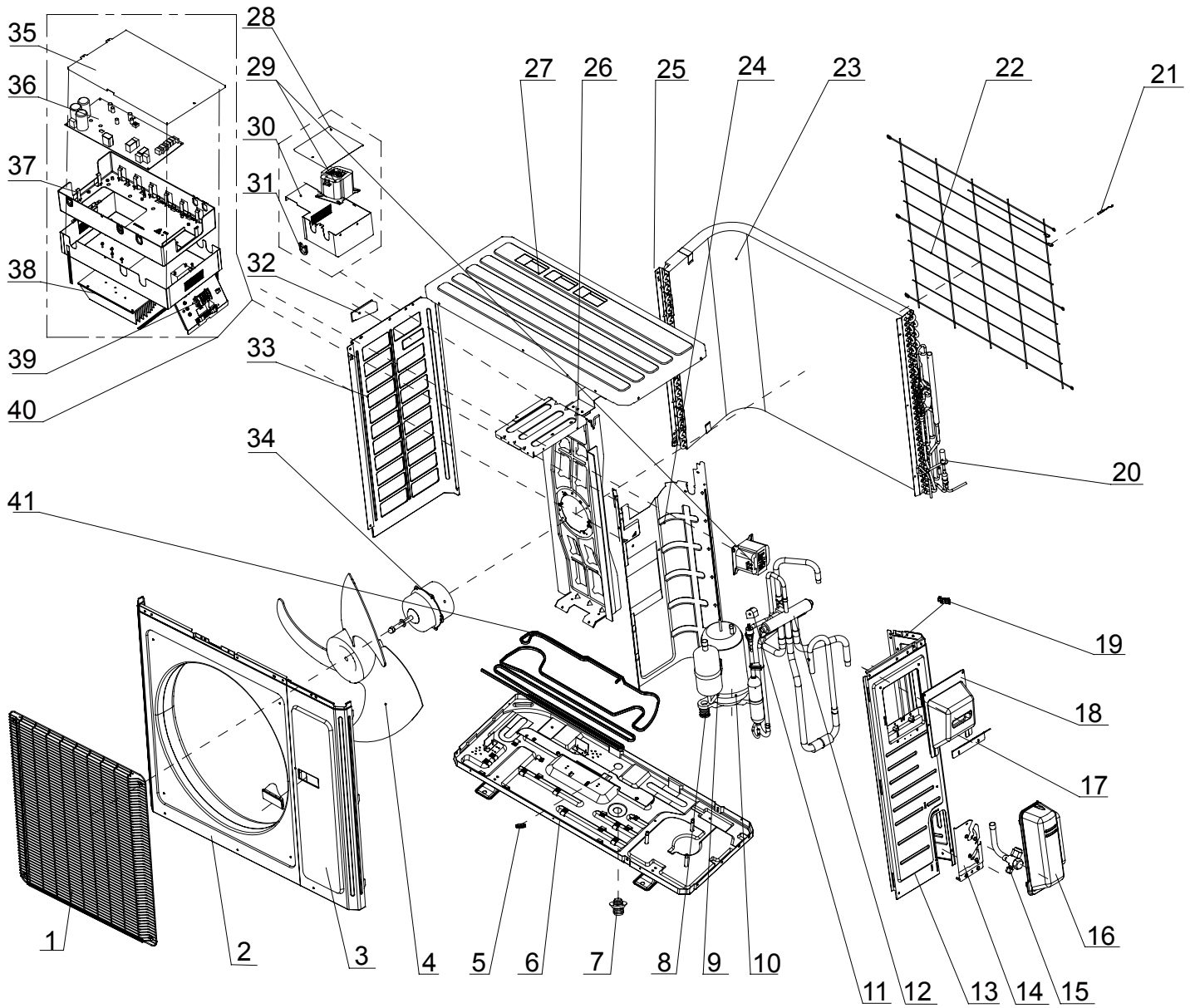

NO.	Description	Part Code	Qty
		IAH36LB-D3DNA3D	
		Part Number	
		700478	
1	Front Grill	01473050	1
2	Cabinet	0143500401P	1
3	Front Side Plate	01303249P	1
4	Axial Flow Fan	10335014	1
5	Drainage Plug	06813401	1
6	Chassis Sub-assy	02803026P	1
7	Drainage Connector	06123401	1
8	Compressor Gasket	76710207	3
9	Compressor and fitting	00205275	1
10	Electrical heater	7651873209	1
11	Magnet Coil	4300040029	1
12	4-way Valve Assy	03123890	1
13	Right Side Plate	0130504402P	1
14	Valve Support Sub-Assy	0171501201P	1
15	Cut-off Valve	07135054	1
16	Valve cover	22245003	1
17	Retaining plate	02115006P	1
18	Handle assy	02113109	1
19	Wiring clamp	26115004	1
20	Electronic expansion valve Sub-Assy	07133688	1
21	Temperature Sensor	3900031001	1
22	Rear Grill	01475013	1
23	Condenser Assy	01163491	1
24	Clapboard	01233134	1
25	Condenser support plate	01175037	1
26	Motor Support Sub-Assy	01802876	1
27	Top Cover Sub-Assy	01255007	1
28	Electric Box Cover	01425279	1
29	Reactor	43130192	2
30	Electric Box Sub-Assy	02603620	1
31	Pass wire ring sub-assy	76614102	2
32	left handle	26233053	1
33	Left Side Plate	01305043P	1
34	Fan Motor	1570280205	1
35	Electric Box Cover	01425281	1
36	Main Board	30138000711	1
37	Electric Box	02603614	1
38	Radiator	49010252	1
39	Terminal Board	4201025501	1
40	Electric Box Assy	10000100328	1
41	Electrical Heater (Chassis)	7651000413	1

Above data is subject to change without notice.

11. Removal Procedure



Warning: Be sure to wait for a minimum of 20 minutes after turning off all power supplies and discharge the refrigerant completely before removal.

11.1 Removal Procedure of Indoor Unit

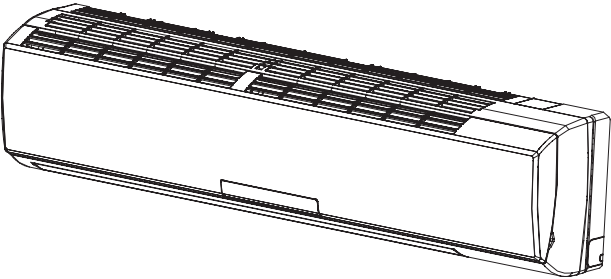
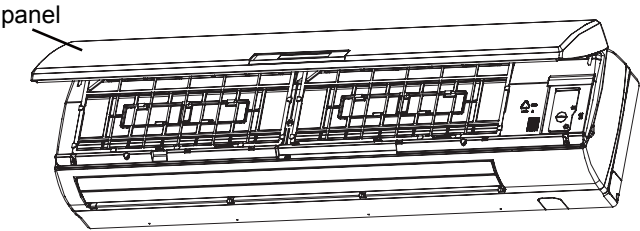
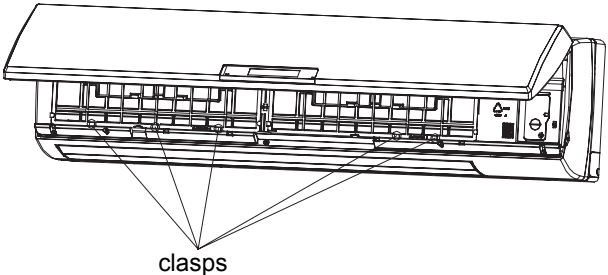
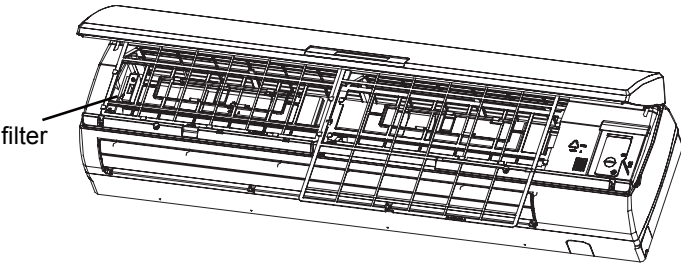
Steps	Procedure	
1. Before disassembly of the unit		
	<p>Axonometric drawing for the complete unit.</p>	
2. Remove filter		
1	Open the panel.	
2	Loosen the clasps on the filter.	
3	Draw out two pieces of filter.	

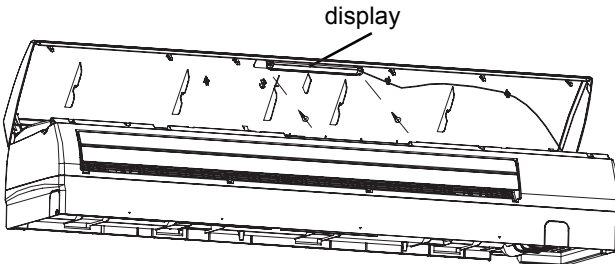
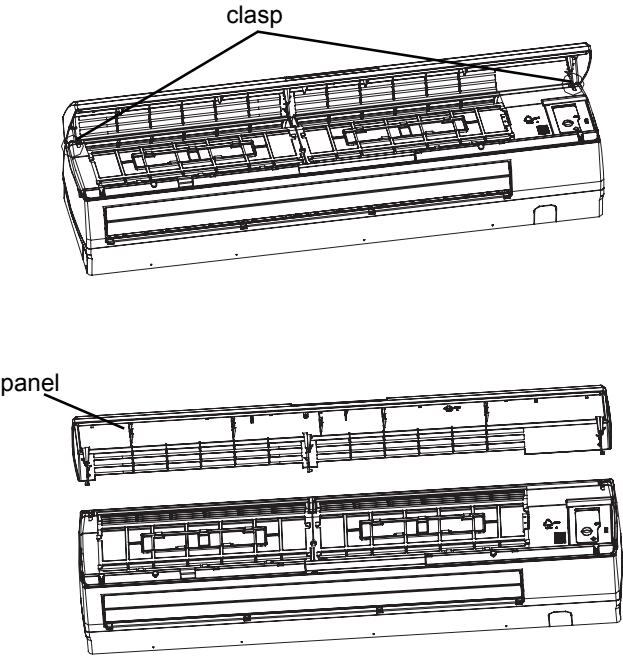
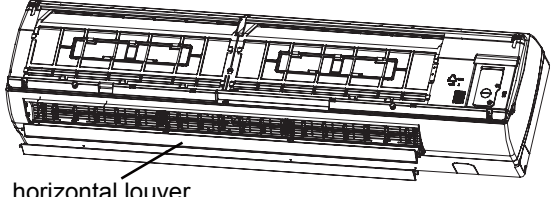
Steps	Procedure	
3.Remove display	Remove 2 screws fixing display, and then remove the filter.	 <p>display</p>
4.Remove panel	Pull the clasps at both sides slightly, and then remove the panel.	 <p>clasp</p> <p>panel</p>
5.Remove horizontal louver	Remove the axial bush on the horizontal louver, and then remove the horizontal louver.	 <p>horizontal louver</p>

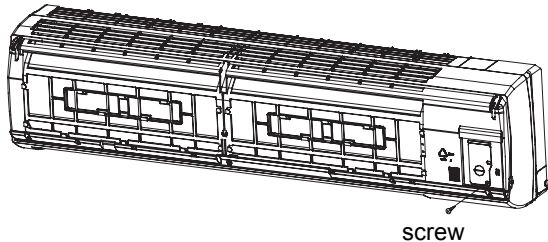
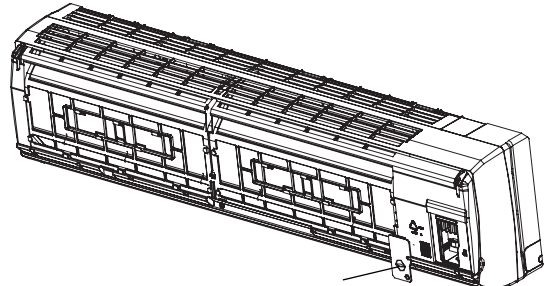
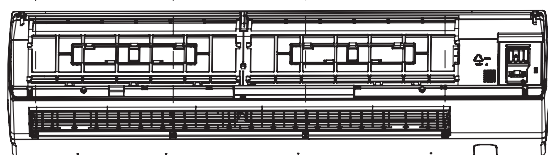
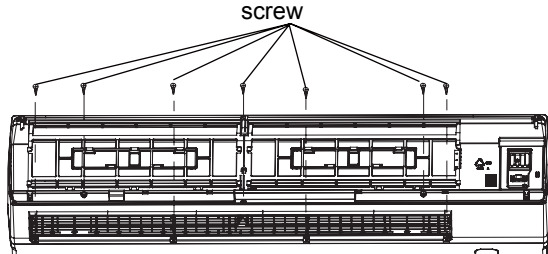
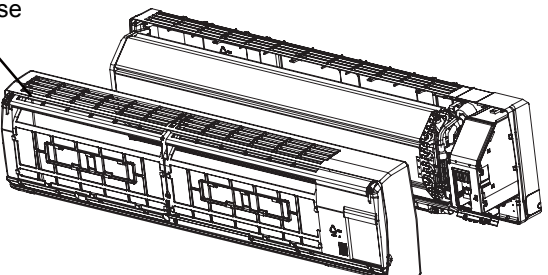
Steps	Procedure	
6.Remove top cover of electric box		
1	Remove screws fixing the top cover of electric box.	 <p>screw</p>
2	Remove the top cover of electric box.	 <p>top cover of electric box</p>
7.Remove front case		
1	Remove the screw caps on front case.	 <p>screw cap</p>
2	Remove screws connecting the front case.	 <p>screw</p>
3	Remove the front case.	 <p>front case</p>

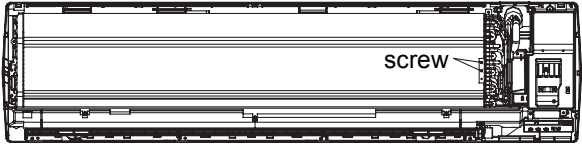
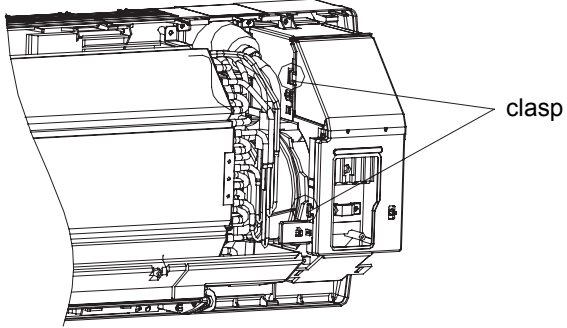
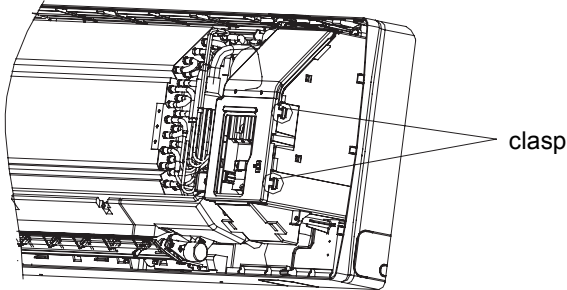
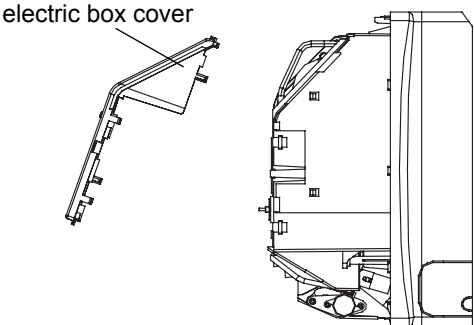
Steps	Procedure
8.Remove earthing wire	 <p data-bbox="1242 425 1307 447">screw</p>
<p data-bbox="235 432 711 491">Remove earthing screws, and then remove the earthing wire.</p>	
9.Remove electric box cover	 <p data-bbox="1396 862 1458 884">clasp</p>  <p data-bbox="1396 1349 1458 1371">clasp</p>  <p data-bbox="824 1644 1019 1666">electric box cover</p>
1	<p data-bbox="235 912 722 941">Loosen clasps at the left side of electric box.</p>
2	<p data-bbox="235 1338 743 1367">Loosen clasps on the right side of electric box.</p>
3	<p data-bbox="235 1764 532 1793">Remove electric box cover.</p>

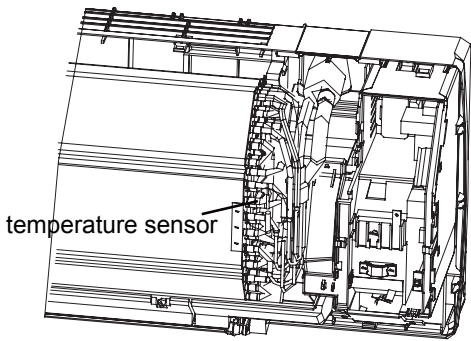
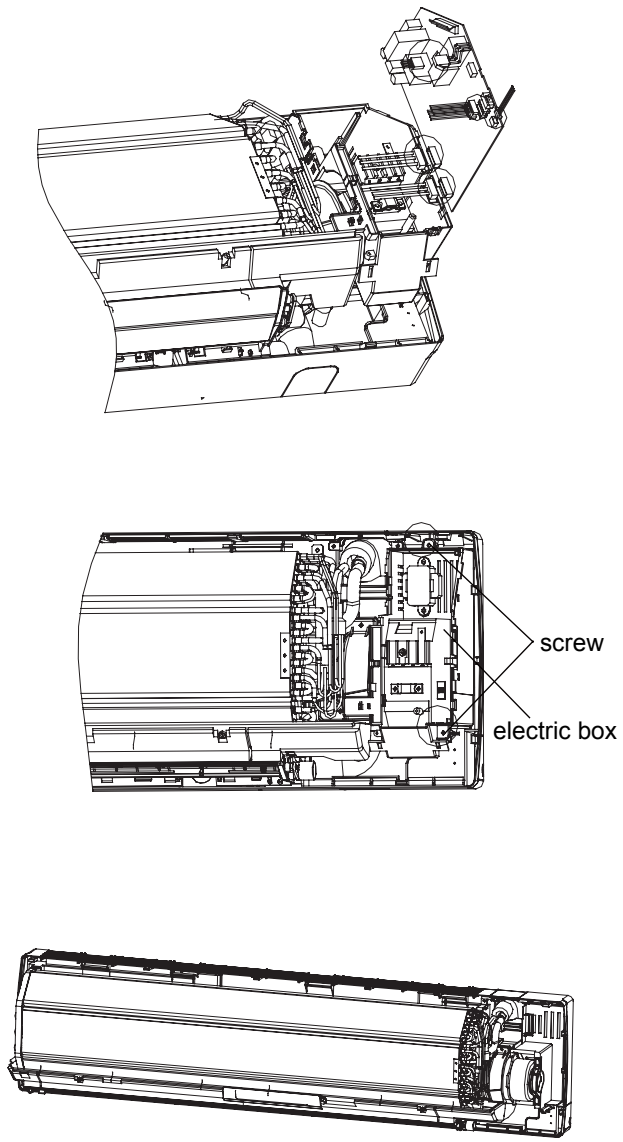
Steps	Procedure	
10.Remove temperature sensor	Pull out the indoor temperature sensor.	 <p>temperature sensor</p>
11.Remove electric box	<p>1 Pull out 6 sockets on PCB board.</p> <p>2 Pull out two screws on electric box.</p> <p>3 Remove the electric box.</p>	 <p>screw</p> <p>electric box</p>

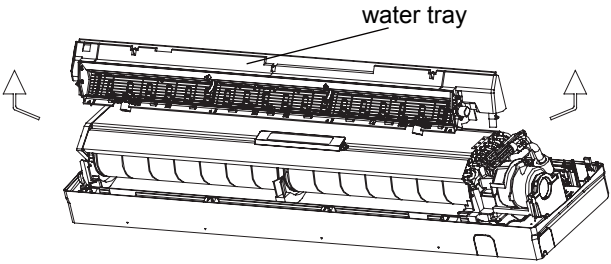
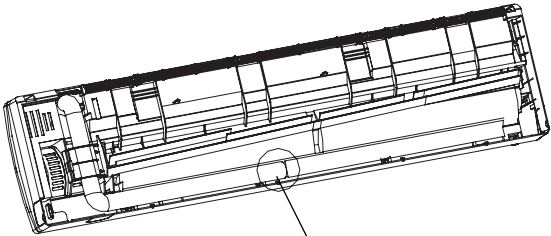
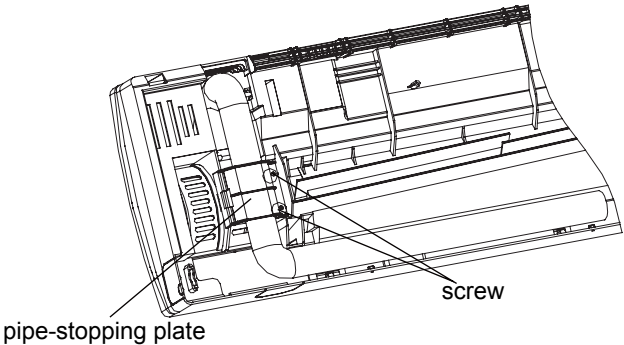
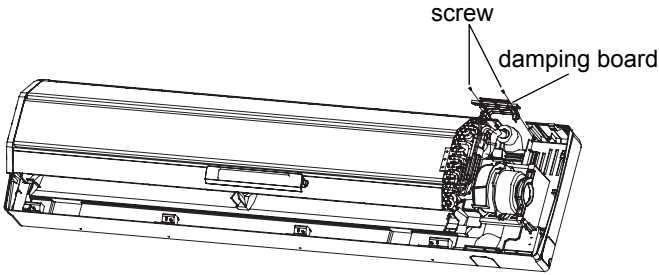
Steps	Procedure	
12.Remove water tray		
	<p>Pull the water tray upwards, and then remove the water tray.</p>	 <p>water tray</p>
13.Remove connection pipe between indoor and outdoor units		
	<p>Separate the connection pipe between indoor and outdoor units.</p>	 <p>connection position for indoor and outdoor units' connection pipe</p>
14.Remove pipe-stopping plate		
	<p>Remove two screws on pipe-stopping plate for indoor unit, and then remove the pipe-stopping plate.</p>	 <p>pipe-stopping plate</p> <p>screw</p>
15.Remove damping board		
	<p>Remove 2 screws on damping board, and then remove the damping board.</p>	 <p>screw</p> <p>damping board</p>

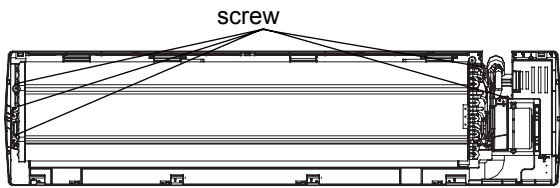
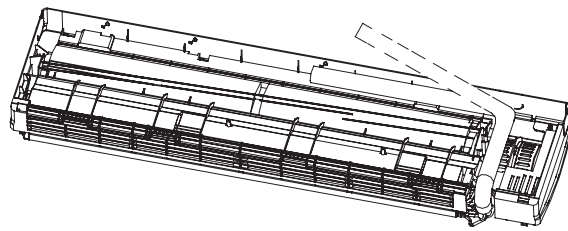
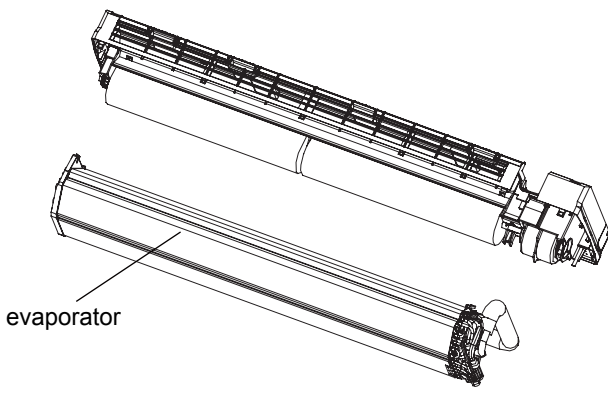
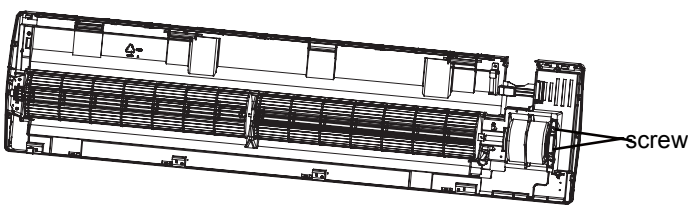
Steps	Procedure	
16.Remove evaporator		
1	Remove screws between evaporator and bottom case.	 <p>A top-down perspective view of the indoor unit. A label 'screw' with a line points to a screw being removed from the bottom case, which is located between the evaporator and the bottom panel.</p>
2	Turn over the indoor unit and adjust the pipe line to the position as shown by the broken line.	 <p>A perspective view of the indoor unit turned over. A dashed line indicates the new position of the pipe line, which is being adjusted to fit the unit's orientation.</p>
3	Lift up the evaporator, and then remove the evaporator.	 <p>A perspective view showing the evaporator being lifted out of the indoor unit. A label 'evaporator' with a line points to the component being removed.</p>
17.Remove the fixing plate of motor		
	Remove 2 screws on fixing plate of motor, and then remove the fixing pate of motor.	 <p>A perspective view of the indoor unit. A label 'screw' with a line points to a screw being removed from the fixing plate of the motor.</p>

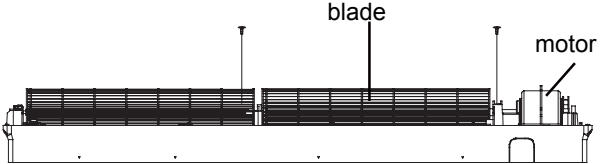
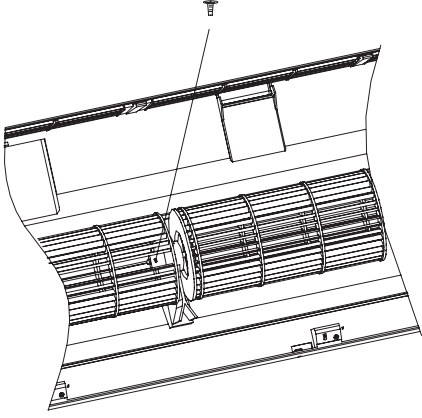
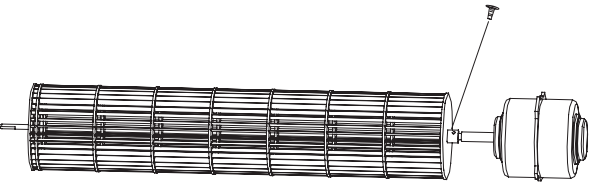
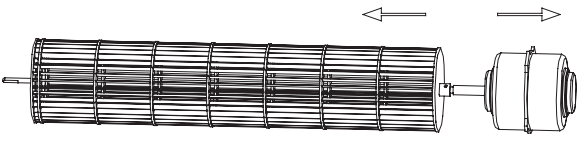
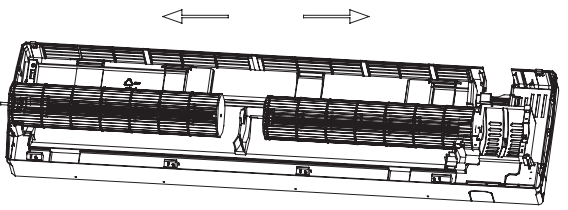
Steps	Procedure
18.Remove cross flow blade and motor	
1	<p>Remove screws fixing cross flow blade and motor.</p>   
2	<p>Remove the motor sub-assy.</p> 
3	<p>Separate two cross flow blade.</p> 

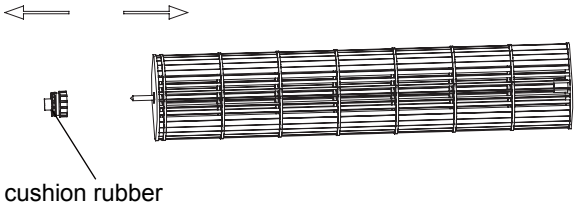
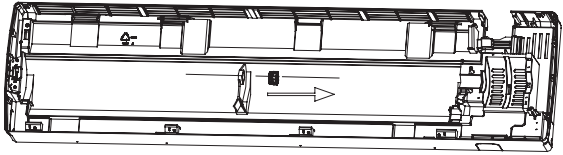
Steps	Procedure	
19.Remove cushion rubber		
1	Remove the cushion rubber on cross flow blade.	 <p>cushion rubber</p>
2	Remove the cushion rubber from the base.	

11.2 Removal Procedure of Outdoor Unit

Note: Take heat pump unit for example.

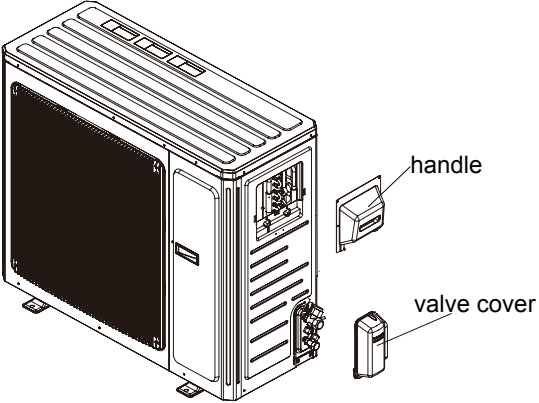
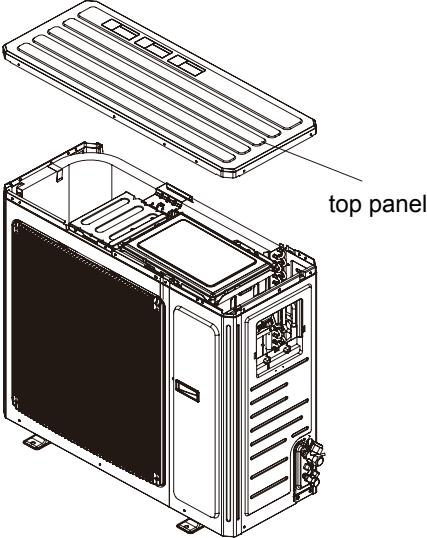
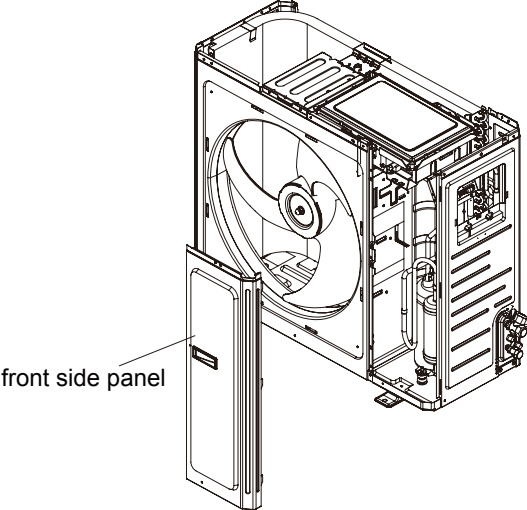
Steps	Procedure
1. Remove big handle, valve cover and top cover	<p data-bbox="196 471 737 596">Remove the screw connecting the big handle and right side plate, and then remove the big handle. Remove the screw connecting the valve cover and right side plate, and then remove the valve cover.</p> 
2. Remove top panel	<p data-bbox="212 1100 667 1192">Remove the screws connecting the top panel with the front panel and left&right side plate, and then remove the top panel.</p> 
3. Remove front side panel	<p data-bbox="212 1686 688 1777">Loosen the screws connecting the front side panel and chassis. Remove the front side panel.</p> 

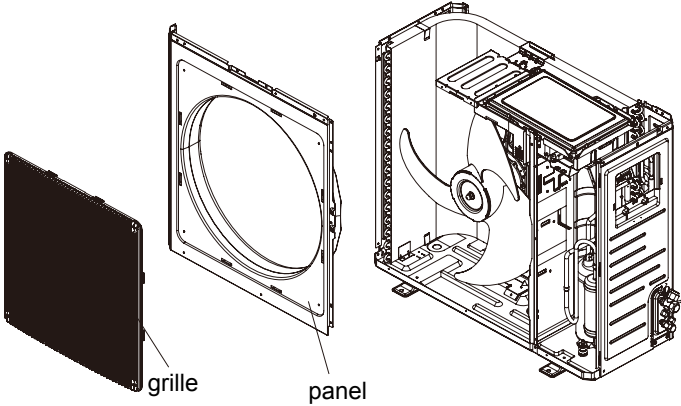
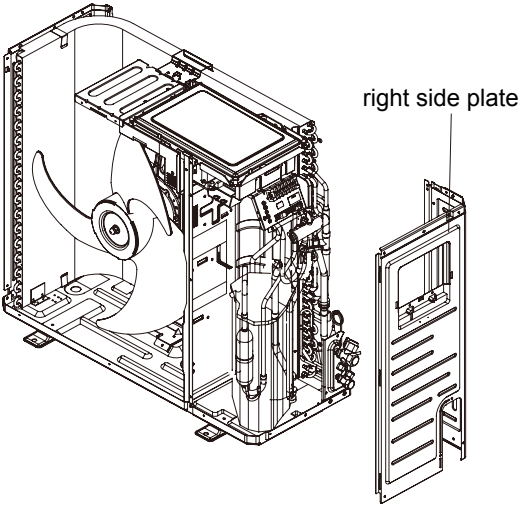
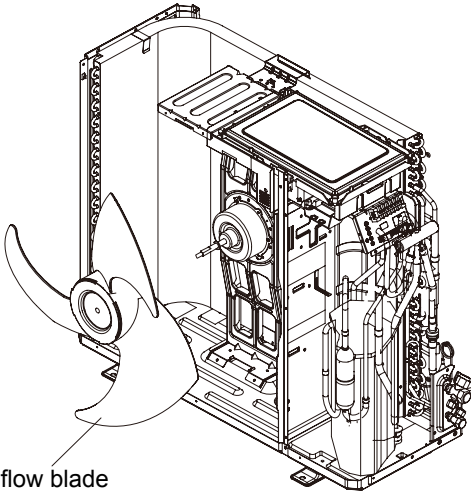
Steps	Procedure
<p>4.Remove grille and panel</p>	<p>Twist off the screws connecting the grille and panel, and then remove the grille.</p> <p>Twist off the screws connecting the panel, chassis and motor support with screwdriver, and then remove the panel.</p> 
<p>5.Remove right side plate</p>	<p>Twist off the screws connecting the right side plate and chassis, valve support and condenser, and then remove the right side plate.</p> 
<p>6.Remove axial flow blade</p>	<p>Twist off the nuts on blade with wrench and then remove the axial flow blade.</p> 

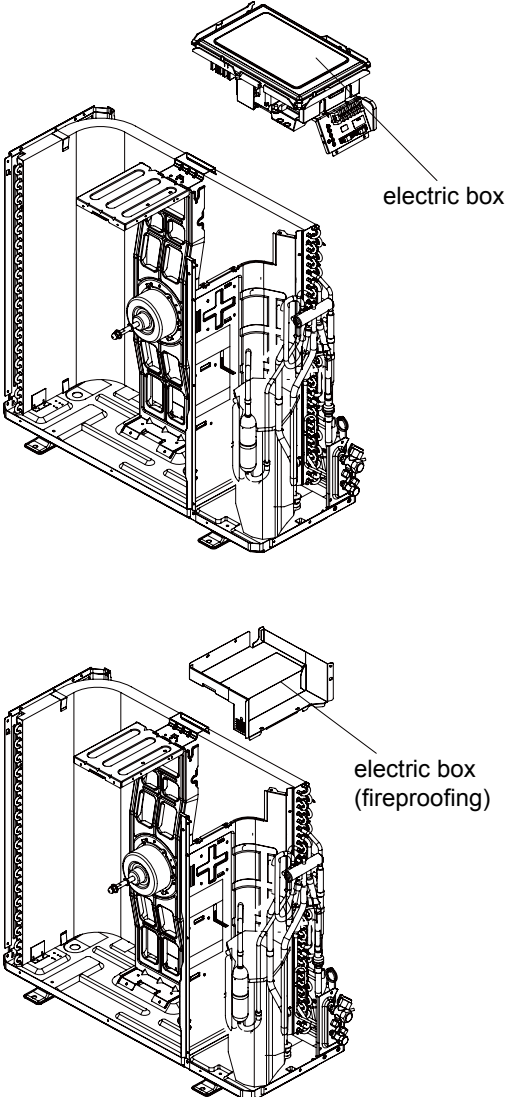
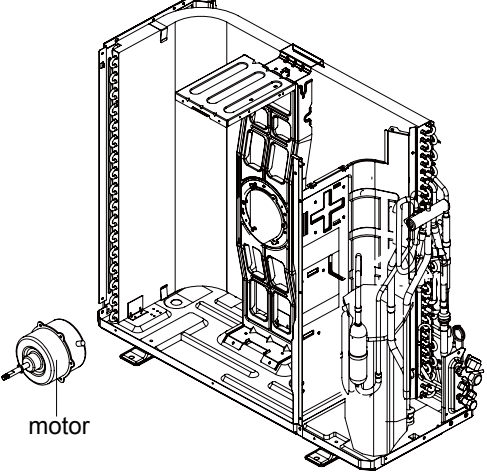
Steps	Procedure
<p>7.Remove electric box</p>	<p>Twist off the screws on electric box, cut off the tieline with scissors or pliers, pull out the wiring terminal, pull it upwards to remove the electric box.</p> <p>Twist off the screws on electric box (fireproofing) with screwdriver, and then remove the electric box (fireproofing).</p>  <p>The diagram consists of two parts. The top part shows a perspective view of the device's internal components. A rectangular electric box is shown being pulled away from the top of the assembly. A label 'electric box' points to this component. The bottom part shows a similar perspective view, but the electric box is now removed, and a fireproofing box is shown being pulled away from the top. A label 'electric box (fireproofing)' points to this component.</p>
<p>8.Remove motor</p>	<p>Twist off the tapping screws fixing the motor, pull out the pin of leading wire for motor and then remove the motor.</p>  <p>The diagram shows a perspective view of the device's internal components. A small cylindrical motor is shown being pulled out from the bottom left of the assembly. A label 'motor' points to this component.</p>

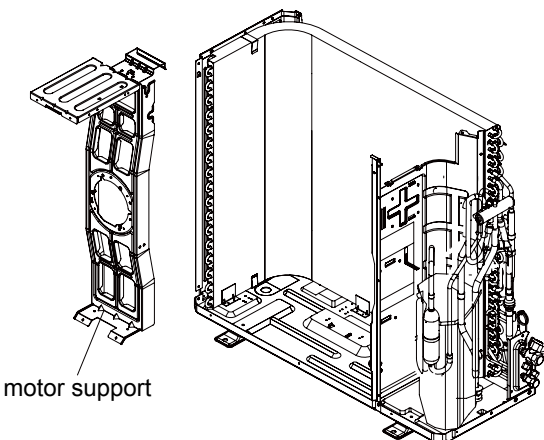
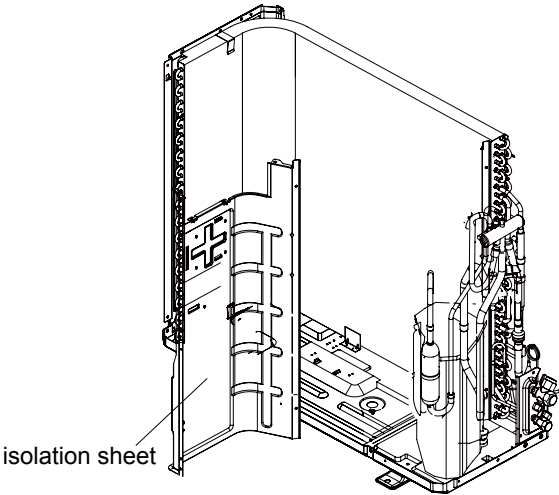
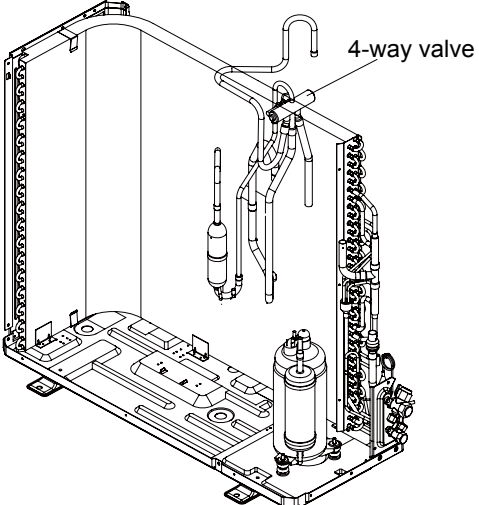
Steps	Procedure
<p>9.Remove motor support</p>	<p>Twist off the tapping screws fixing the motor support, pull it upwards and then remove the motor support.</p> 
<p>10.Remove isolation sheet</p>	<p>Twist off the screws connecting isolation sheet and end plate of condenser and chassis, and then remove the isolation sheet.</p> 
<p>11.Remove 4-way valve</p>	<p>Unsolder the pipeline between compressor, condenser, gas and liquid valve, and then remove the 4-way valve. (note: release all refrigerant before unsoldering).</p> 

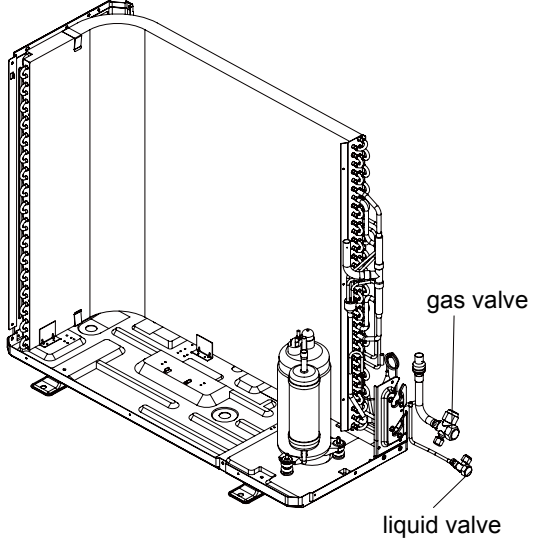
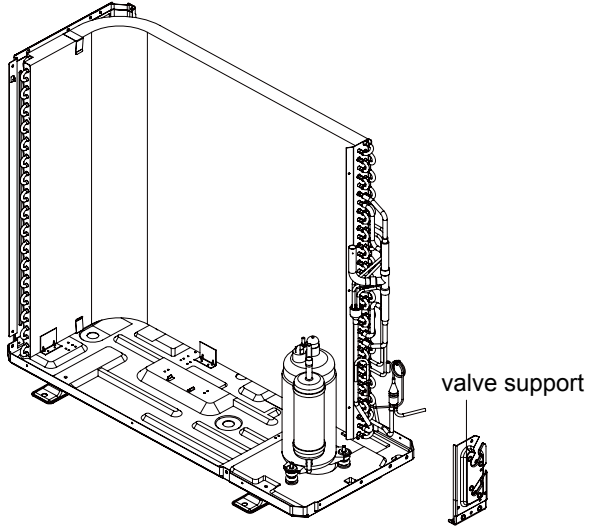
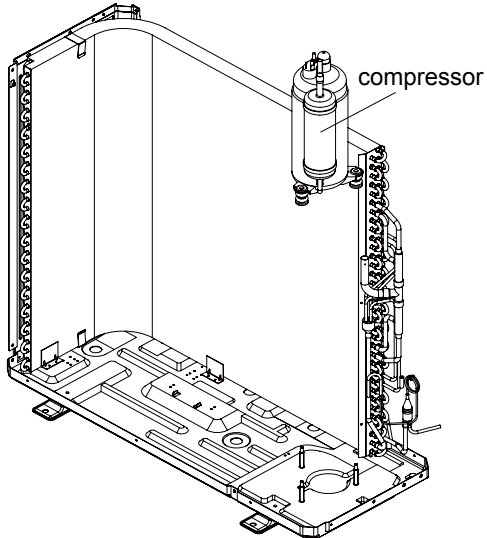
Steps	Procedure
<p>12.Remove gas valve and liquid valve</p>	<p>Twist off the 2 bolts fixing the valve sub-assy. Unsolder the soldering joint between gas valve and air-return pipe and then remove the gas valve.(note: when unsoldering the soldering joint, wrap the gas valve with wet cloth completely to avoid the damage to valve, and release all refrigerant completely at first). Unsolder the soldering joint between liquid valve and connection pipe of liquid valve, and then remove the liquid valve.</p> 
<p>13.Remove valve support</p>	<p>Twist off the screws connecting valve support and chassis, and then remove the valve support.</p> 
<p>14.Remove compressor</p>	<p>Twist off the 3 foot nuts on compressor and then remove the compressor.</p> 

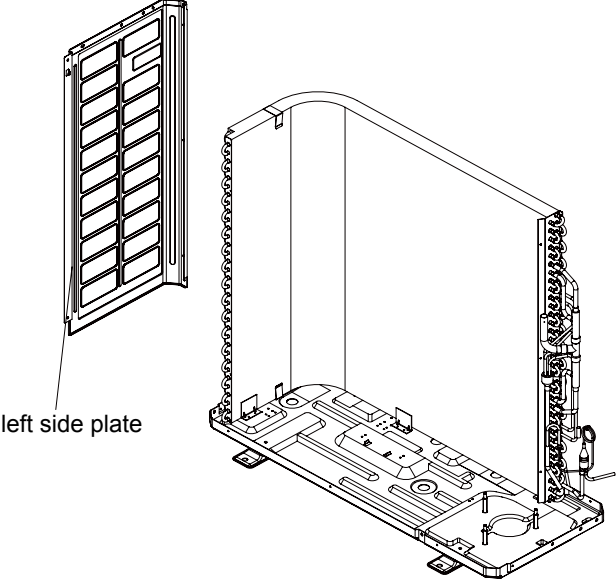
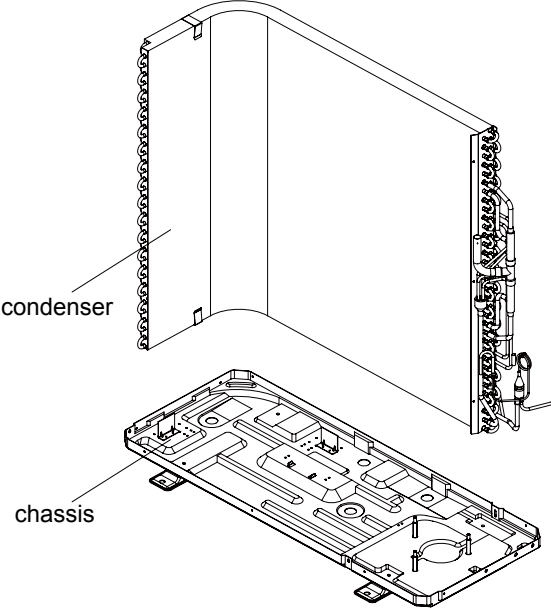
Steps	Procedure
15.Remove left side plate	<p data-bbox="207 410 734 497">Twist off the screws connecting the left side plate and chassis with screwdriver, and then remove the left side plate.</p>  <p data-bbox="841 666 982 694">left side plate</p>
16.Remove chassis and condenser	<p data-bbox="207 1054 669 1120">Pull it upwards to separate the chassis and condenser.</p>  <p data-bbox="841 1153 954 1181">condenser</p> <p data-bbox="857 1360 938 1389">chassis</p>

Appendix:

Appendix 1: Reference Sheet of Celsius and Fahrenheit

Conversion formula for Fahrenheit degree and Celsius degree: $T_f = T_c \times 1.8 + 32$

Set temperature

Fahrenheit display temperature (°F)	Fahrenheit (°F)	Celsius (°C)	Fahrenheit display temperature (°F)	Fahrenheit (°F)	Celsius (°C)	Fahrenheit display temperature (°F)	Fahrenheit (°F)	Celsius (°C)
61	60.8	16	69/70	69.8	21	78/79	78.8	26
62/63	62.6	17	71/72	71.6	22	80/81	80.6	27
64/65	64.4	18	73/74	73.4	23	82/83	82.4	28
66/67	66.2	19	75/76	75.2	24	84/85	84.2	29
68	68	20	77	77	25	86	86	30

Ambient temperature

Fahrenheit display temperature (°F)	Fahrenheit (°F)	Celsius (°C)	Fahrenheit display temperature (°F)	Fahrenheit (°F)	Celsius (°C)	Fahrenheit display temperature (°F)	Fahrenheit (°F)	Celsius (°C)
32/33	32	0	55/56	55.4	13	79/80	78.8	26
34/35	33.8	1	57/58	57.2	14	81	80.6	27
36	35.6	2	59/60	59	15	82/83	82.4	28
37/38	37.4	3	61/62	60.8	16	84/85	84.2	29
39/40	39.2	4	63	62.6	17	86/87	86	30
41/42	41	5	64/65	64.4	18	88/89	87.8	31
43/44	42.8	6	66/67	66.2	19	90	89.6	32
45	44.6	7	68/69	68	20	91/92	91.4	33
46/47	46.4	8	70/71	69.8	21	93/94	93.2	34
48/49	48.2	9	72	71.6	22	95/96	95	35
50/51	50	10	73/74	73.4	23	97/98	96.8	36
52/53	51.8	11	75/76	75.2	24	99	98.6	37
54	53.6	12	77/78	77	25			

Appendix 2: Configuration of Connection Pip

- Standard length of connection pipe
 - 16.40ft, 24.61ft, 26.25ft.
- Min. length of connection pipe is 9.84ft.
- Max. length of connection pipe and max. high difference.
- The additional refrigerant oil and refrigerant charging required after prolonging connection pipe
 - After the length of connection pipe is prolonged for 32.81ft at the basis of standard length, you should add 5ml of refrigerant oil for each additional 16.40ft of connection pipe.
 - The calculation method of additional refrigerant charging amount (on the basis of liquid pipe):
 - When the length of connection pipe is above 16.40ft, add refrigerant according to the prolonged length of liquid pipe. The additional refrigerant charging amount per meter is different according to the diameter of liquid pipe. See the following sheet.
 - Additional refrigerant charging amount = prolonged length of liquid pipe X additional refrigerant charging amount per meter

Cooling capacity	Max length of connection pipe	Max height difference
5000 Btu/h(1465 W)	49.21ft	16.40ft
7000 Btu/h(2051 W)	49.21ft	16.40ft
9000 Btu/h(2637 W)	49.21ft	32.81ft
12000 Btu/h(3516 W)	65.62ft	32.81ft
18000 Btu/h(5274 W)	80.02ft	32.81ft
24000 Btu/h(7032 W)	80.02ft	32.81ft
28000 Btu/h(8204 W)	98.43ft	32.81ft
36000 Btu/h(10548 W)	98.43ft	65.62ft
42000 Btu/h(12306 W)	98.43ft	65.62ft
48000 Btu/h(14064 W)	98.43ft	65.62ft

Additional refrigerant charging amount for R22, R407C, R410A and R134a			
Diameter of connection pipe		Outdoor unit throttle	
Liquid pipe(inch)	Gas pipe(inch)	Cooling only(oz/ft.)	Cooling and heating(oz/ft.)
Φ1/4	Φ3/8or Φ1/2	0.2	0.2
Φ1/4 or Φ3/8	Φ5/8 or Φ3/4	0.2	0.5
Φ1/2	Φ3/4 or Φ7/8	0.3	1.3
Φ5/8	Φ1 or Φ1 1/4	0.6	1.3
Φ3/4	/	2.7	2.7
Φ7/8	/	3.8	3.8



Appendix 3: Pipe Expanding Method

⚠ Note:

Improper pipe expanding is the main cause of refrigerant leakage. Please expand the pipe according to the following steps:

A: Cut the pip

- Confirm the pipe length according to the distance of indoor unit and outdoor unit
- Cut the required pipe with pipe cutter.

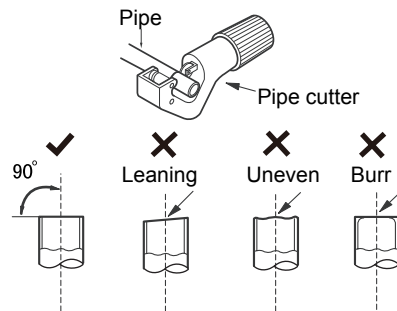

B: Remove the burrs

- Remove the burrs with shaper and prevent the burrs from getting into the pipe.

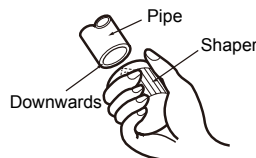

C: Put on suitable insulating pipe

D: Put on the union nut

- Remove the union nut on the indoor connection pipe and outdoor valve; install the union nut on the pipe.

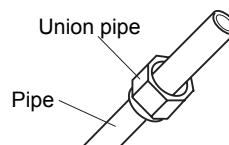

E: Expand the port

- Expand the port with expander.

⚠ Note:

- "A" is different according to the diameter, please refer to the sheet below:

Outer diameter(inch)	A(inch)	
	Max	Min
Φ1/4	2/39	1/36
Φ3/8	1/16	1/51
Φ1/2	1/14	1/51
Φ5/8	5/53	2/23

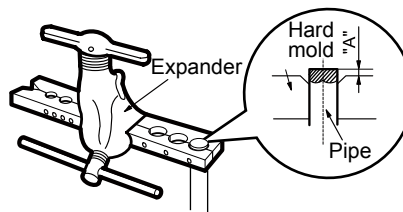

F: Inspection

- Check the quality of expanding port. If there is any blemish, expand the port again according to the steps above.

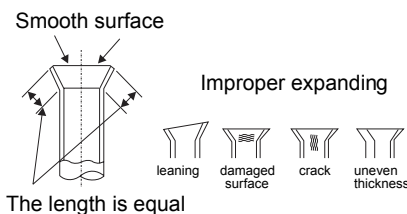

STOP

This product is precharged with refrigerant for a **25 feet** of line set.

If **MORE** than 25 feet of line set is required, refer to your Ideal-Air Service Manual for refrigerant charging chart.

For line sets between 25' & 10' in length, **REMOVE .65 oz** of R410A refrigerant per line feed.

According to manufacturer's specifications, under no circumstances should the line set be shorter than 10' in length.

If you need further assistance, please contact:
Ideal-Air Tech Support
 877-943-3251
 support@ideal-air.com

Appendix 4: List of Resistance for Temperature Sensor

Resistance Table of Ambient Temperature Sensor for Indoor and Outdoor Units(15K)

Temp.(°F)	Resistance(kΩ)	Temp.(°F)	Resistance(kΩ)	Temp.(°F)	Resistance(kΩ)	Temp.(°F)	Resistance(kΩ)
-2.2	138.1	68	18.75	138.2	3.848	208.4	1.071
-0.4	128.6	69.8	17.93	140	3.711	210.2	1.039
1.4	121.6	71.6	17.14	141.8	3.579	212	1.009
3.2	115	73.4	16.39	143.6	3.454	213.8	0.98
5	108.7	75.2	15.68	145.4	3.333	215.6	0.952
6.8	102.9	77	15	147.2	3.217	217.4	0.925
8.6	97.4	78.8	14.36	149	3.105	219.2	0.898
10.4	92.22	80.6	13.74	150.8	2.998	221	0.873
12.2	87.35	82.4	13.16	152.6	2.896	222.8	0.848
14	82.75	84.2	12.6	154.4	2.797	224.6	0.825
15.8	78.43	86	12.07	156.2	2.702	226.4	0.802
17.6	74.35	87.8	11.57	158	2.611	228.2	0.779
19.4	70.5	89.6	11.09	159.8	2.523	230	0.758
21.2	66.88	91.4	10.63	161.6	2.439	231.8	0.737
23	63.46	93.2	10.2	163.4	2.358	233.6	0.717
24.8	60.23	95	9.779	165.2	2.28	235.4	0.697
26.6	57.18	96.8	9.382	167	2.206	237.2	0.678
28.4	54.31	98.6	9.003	168.8	2.133	239	0.66
30.2	51.59	100.4	8.642	170.6	2.064	240.8	0.642
32	49.02	102.2	8.297	172.4	1.997	242.6	0.625
33.8	46.6	104	7.967	174.2	1.933	244.4	0.608
35.6	44.31	105.8	7.653	176	1.871	246.2	0.592
37.4	42.14	107.6	7.352	177.8	1.811	248	0.577
39.2	40.09	109.4	7.065	179.6	1.754	249.8	0.561
41	38.15	111.2	6.791	181.4	1.699	251.6	0.547
42.8	36.32	113	6.529	183.2	1.645	253.4	0.532
44.6	34.58	114.8	6.278	185	1.594	255.2	0.519
46.4	32.94	116.6	6.038	186.8	1.544	257	0.505
48.2	31.38	118.4	5.809	188.6	1.497	258.8	0.492
50	29.9	120.2	5.589	190.4	1.451	260.6	0.48
51.8	28.51	122	5.379	192.2	1.408	262.4	0.467
53.6	27.18	123.8	5.197	194	1.363	264.2	0.456
55.4	25.92	125.6	4.986	195.8	1.322	266	0.444
57.2	24.73	127.4	4.802	197.6	1.282	267.8	0.433
59	23.6	129.2	4.625	199.4	1.244	269.6	0.422
60.8	22.53	131	4.456	201.2	1.207	271.4	0.412
62.6	21.51	132.8	4.294	203	1.171	273.2	0.401
64.4	20.54	134.6	4.139	204.8	1.136	275	0.391
66.2	19.63	136.4	3.99	206.6	1.103	276.8	0.382

Resistance Table of Tube Temperature Sensors for Indoor and Outdoor (20K)

Temp.(°F)	Resistance(kΩ)	Temp.(°F)	Resistance(kΩ)	Temp.(°F)	Resistance(kΩ)	Temp.(°F)	Resistance(kΩ)
-2.2	181.4	68	25.01	138.2	5.13	208.4	1.427
-0.4	171.4	69.8	23.9	140	4.948	210.2	1.386
1.4	162.1	71.6	22.85	141.8	4.773	212	1.346
3.2	153.3	73.4	21.85	143.6	4.605	213.8	1.307
5	145	75.2	20.9	145.4	4.443	215.6	1.269
6.8	137.2	77	20	147.2	4.289	217.4	1.233
8.6	129.9	78.8	19.14	149	4.14	219.2	1.198
10.4	123	80.6	18.13	150.8	3.998	221	1.164
12.2	116.5	82.4	17.55	152.6	3.861	222.8	1.131
14	110.3	84.2	16.8	154.4	3.729	224.6	1.099
15.8	104.6	86	16.1	156.2	3.603	226.4	1.069
17.6	99.13	87.8	15.43	158	3.481	228.2	1.039
19.4	94	89.6	14.79	159.8	3.364	230	1.01
21.2	89.17	91.4	14.18	161.6	3.252	231.8	0.983
23	84.61	93.2	13.59	163.4	3.144	233.6	0.956
24.8	80.31	95	13.04	165.2	3.04	235.4	0.93
26.6	76.24	96.8	12.51	167	2.94	237.2	0.904
28.4	72.41	98.6	12	168.8	2.844	239	0.88
30.2	68.79	100.4	11.52	170.6	2.752	240.8	0.856
32	65.37	102.2	11.06	172.4	2.663	242.6	0.833
33.8	62.13	104	10.62	174.2	2.577	244.4	0.811
35.6	59.08	105.8	10.2	176	2.495	246.2	0.77
37.4	56.19	107.6	9.803	177.8	2.415	248	0.769
39.2	53.46	109.4	9.42	179.6	2.339	249.8	0.746
41	50.87	111.2	9.054	181.4	2.265	251.6	0.729
42.8	48.42	113	8.705	183.2	2.194	253.4	0.71
44.6	46.11	114.8	8.37	185	2.125	255.2	0.692
46.4	43.92	116.6	8.051	186.8	2.059	257	0.674
48.2	41.84	118.4	7.745	188.6	1.996	258.8	0.658
50	39.87	120.2	7.453	190.4	1.934	260.6	0.64
51.8	38.01	122	7.173	192.2	1.875	262.4	0.623
53.6	36.24	123.8	6.905	194	1.818	264.2	0.607
55.4	34.57	125.6	6.648	195.8	1.736	266	0.592
57.2	32.98	127.4	6.403	197.6	1.71	267.8	0.577
59	31.47	129.2	6.167	199.4	1.658	269.6	0.563
60.8	30.04	131	5.942	201.2	1.609	271.4	0.549
62.6	28.68	132.8	5.726	203	1.561	273.2	0.535
64.4	27.39	134.6	5.519	204.8	1.515	275	0.521
66.2	26.17	136.4	5.32	206.6	1.47	276.8	0.509

Resistance Table of Discharge Temperature Sensor for Outdoor(50K)

Temp.(°F)	Resistance(kΩ)	Temp.(°F)	Resistance(kΩ)	Temp.(°F)	Resistance(kΩ)	Temp.(°F)	Resistance(kΩ)
-20.2	853.5	50	98	120.2	18.34	190.4	4.754
-18.4	799.8	51.8	93.42	122	17.65	192.2	4.609
-16.6	750	53.6	89.07	123.8	16.99	194	4.469
-14.8	703.8	55.4	84.95	125.6	16.36	195.8	4.334
-13	660.8	57.2	81.05	127.4	15.75	197.6	4.204
-11.2	620.8	59	77.35	129.2	15.17	199.4	4.079
-9.4	580.6	60.8	73.83	131	14.62	201.2	3.958
-7.6	548.9	62.6	70.5	132.8	14.09	203	3.841
-5.8	516.6	64.4	67.34	134.6	13.58	204.8	3.728
-4	486.5	66.2	64.33	136.4	13.09	206.6	3.619
-2.2	458.3	68	61.48	138.2	12.62	208.4	3.514
-0.4	432	69.8	58.77	140	12.17	210.2	3.413
1.4	407.4	71.6	56.19	141.8	11.74	212	3.315
3.2	384.5	73.4	53.74	143.6	11.32	213.8	3.22
5	362.9	75.2	51.41	145.4	10.93	215.6	3.129
6.8	342.8	77	49.19	147.2	10.54	217.4	3.04
8.6	323.9	78.8	47.08	149	10.18	219.2	2.955
10.4	306.2	80.6	45.07	150.8	9.827	221	2.872
12.2	289.6	82.4	43.16	152.6	9.489	222.8	2.792
14	274	84.2	41.34	154.4	9.165	224.6	2.715
15.8	259.3	86	39.61	156.2	8.854	226.4	2.64
17.6	245.6	87.8	37.96	158	8.555	228.2	2.568
19.4	232.6	89.6	36.38	159.8	8.268	230	2.498
21.2	220.5	91.4	34.88	161.6	7.991	231.8	2.431
23	209	93.2	33.45	163.4	7.726	233.6	2.365
24.8	198.3	95	32.09	165.2	7.47	235.4	2.302
26.6	199.1	96.8	30.79	167	7.224	237.2	2.241
28.4	178.5	98.6	29.54	168.8	6.998	239	2.182
30.2	169.5	100.4	28.36	170.6	6.761	240.8	2.124
32	161	102.2	27.23	172.4	6.542	242.6	2.069
33.8	153	104	26.15	174.2	6.331	244.4	2.015
35.6	145.4	105.8	25.11	176	6.129	246.2	1.963
37.4	138.3	107.6	24.13	177.8	5.933	248	1.912
39.2	131.5	109.4	23.19	179.6	5.746	249.8	1.863
41	125.1	111.2	22.29	181.4	5.565	251.6	1.816
42.8	119.1	113	21.43	183.2	5.39	253.4	1.77
44.6	113.4	114.8	20.6	185	5.222	255.2	1.725
46.4	108	116.6	19.81	186.8	5.06	257	1.682
48.2	102.8	118.4	19.06	188.6	4.904	258.8	1.64



IDEALair™

PRO SERIES

Limited Warranty Statement

Ideal Air™ Pro Series

APPLICABLE PRODUCTS:

Pro Series Mini Split Air Conditioners and Heat Pumps (Part #'s 700476, 700478, 700480, 700482)

WARRANTY: Ideal Air & Sunlight Supply, Inc. warrants to the original owner of this product, should it prove defective by reason of improper workmanship and/or material, that the defective parts are warranted for a period of ONE YEAR. This warranty is not transferrable.

DIRECTIONS FOR WARRANTY CLAIMS: The following specific steps must be followed to qualify for warranty claim:

1. DO NOT return the product to the reseller from where it was purchased. Instead, please contact Ideal Air Support at (877) 9-IDEAL-1 or support@Ideal-Air.com. Ideal Air Technical Support will provide troubleshooting assistance to help identify any failed parts, and determine if the item qualifies under the terms and conditions below.
2. If a product is authorized for warranty by Ideal Air, the owner may choose from one of three options below:
 - a. Ideal Air will provide a new or refurbished part and provide phone technical support to help the owner make the repair themselves;
 - b. For difficult repairs, Ideal Air will pay (up to \$300 per repair) for a qualified professional repair technician to perform a repair and provide the warranted replacement part;
 - c. The owner can request to have Ideal Air Technicians perform the repair, provided the owner pays the shipping costs to deliver the product to the Ideal Air repair location. Ideal Air will make needed repairs and pay for shipment of the product back to the owner.

TERMS AND CONDITIONS:

- A. **REPLACEMENT PARTS.** Ideal Air & Sunlight Supply, Inc. will replace any defective part without charge for the part, for a period of 1 year. Replacement parts are warranted for the remainder of the original applicable warranty period. Defective parts may be required to be supplied to Sunlight Supply, Inc. in exchange for the replacement part and become the property of Sunlight Supply, Inc.
- B. **NO LABOR.** This limited warranty DOES NOT INCLUDE LABOR or any other costs incurred for service, or replacement of the parts or product except where pre-approved by Ideal Air Technical Support. This includes maintenance, repair, removing, replacing, installing, complying with local building and electric codes, shipping or handling.
- C. **MAINTENANCE REQUIRED.** Ideal Air products are designed to be maintained by the owner, and the owner is solely responsible for all labor and other costs involved in owner-required maintenance. Instructions for air filter cleaning and other maintenance procedures can be found in the Owner's Manual for the product. Failure to maintain an Ideal Air product will VOID its warranty.
- D. **PROPER INSTALLATION.** This Limited Warranty applies only to products that are installed according to the INSTALLATION INSTRUCTIONS. Failure to adhere to the Installation Instructions will VOID this warranty.
- E. **MODIFICATIONS.** Modifications to the equipment or systems will VOID this warranty.
- F. **PROOF OF WARRANTY QUALIFICATION:** The warranty period begins at the time of purchase. Proof of Purchase shall be an **original sales receipt**. It is strongly suggested that end-users save their sales receipt. In the absence of the sales receipt, the warranty period shall begin 90 days after the date of manufacture found on unit (in some cases, within the serial number).
- G. **EXCLUSIONS:** This limited warranty DOES NOT COVER: property damages, malfunction or failure of the product, or personal injury caused by or resulting from: (a) accident, abuse, negligence or misuse; (b) operating the product in a corrosive or wet environment including but not limited to hazardous chemicals; (c) products that have had a serial number or any part thereof altered, defaced or removed; (d) product used and/or installed in any manner contrary to the Installation and/or Operation Manual; or (e) damage caused by force majeure or the result of power surge damage caused by lightning and fluctuations in or interruptions of electrical power. Owners are strongly encouraged to be prepared by keeping a back-up source of heating/cooling in case of emergency.
- H. **LIMITATIONS:** This Limited Warranty shall not be enlarged, extended or affected by:
 - a. Any technical advice, information, and/or service to Owner in connection with the product.
 - b. Under no circumstances shall Ideal Air be held liable for: (i) damages to person or property; (ii) loss of revenue or profit; (iii) removal or disposal of system, resulting from any product defect.
 - c. This Limited Warranty is valid only in the continental United States, Alaska and Hawaii, and it is not transferable.



National Garden Wholesale.
Sunlight Supply, Inc.

IdealAir · National Garden Wholesale, Sunlight Supply Inc. · Vancouver, WA. USA · Version 01/ 2015

Call our Toll Free number for top-rate technical support: 877-9-IDEAL-1 (877-943-3251) · Outside the USA? Call +1-360-546-6161

IDEALair
COMMERCIAL-GRADE



Call our Toll Free number for top-rate technical support:
877-9-IDEAL-1 (877-943-3251)

Outside the USA? Call +1-360-546-6161

Exclusively distributed by:

 National Garden Wholesale,
Sunlight Supply Inc.

www.sunlightsupply.com

For product improvement, specifications and appearance in this manual are subject to change without prior notice.